



Dichiarazione CE di conformità
EC declaration of conformity

Torino, 1/1/2010

REER SpA
via Carcano 32
10153 – Torino
Italy

dichiara che le barriere fotoelettriche **JANUS TRX / M TRX** sono Dispositivi Elettrosensibili di Sicurezza (ESPE) di :

- **Tipo 4** (secondo la Norma *CEI EN 61496-1:2005; CEI EN 61496-2:2007*)
- **SIL 3** (secondo la Norma *CEI EN 61508:2002*)
- **SILCL 3** (secondo la Norma *CEI EN 62061:2005 + CEI EN 62061/EC2:2008*)
- **PL e** (secondo la Norma *UNI EN ISO 13849-1:2008*)

declares that the **JANUS TRX / M TRX** photoelectric safety barriers are :

- **Type 4** (according the Standard *IEC 61496-1:2004; IEC 61496-2:2006*)
- **SIL 3** (according the Standard *IEC 61508:1998*)
- **SILCL 3** (according the Standard *IEC 62061:2005*)
- **PL e** (according the Standard *ISO 13849-1:2006*)

Electro-sensitive Protective Equipments (ESPE)

realizzati in conformità alle seguenti Direttive Europee:
complying with the following European Directives:

- **2006/42/CE** "Direttiva Macchine"
"Machine Directive"
- **2004/108/CE** "Direttiva Compatibilità Elettromagnetica"
"Electromagnetic Compatibility Directive"
- **2006/95/CE** "Direttiva Bassa Tensione"
"Low Voltage Directive"

e sono identiche all'esemplare esaminato ed approvato con esame di tipo CE da:
and are identical to the specimen examined and approved with a CE - type approval by:

TÜV SÜD Rail GmbH – Ridlerstrasse 65 – D-80339 – Muenchen – Germany

Carlo Pautasso
Direttore Tecnico
Technical Director

Giancarlo Scaravelli
Presidente
President

TYPE 4 SAFETY LIGHT CURTAIN

MI TRX / MI TRX L / ML TRX / MT TRX / J TRXL

SUMMARY

INTRODUCTION	2
PRINCIPLE OF OPERATION	3
<i>MUTING FUNCTION</i>	4
MODELS MI TRX	5
MI models used with "I" operational logic	6
CONNECTION WITH 4 EXTERNAL SENSORS	6
MODELS MI TRX L	8
ML TRX MODELS	8
SERIES "ML" - KIT PREASSEMBLED OF MI/ML/MT TRX LIGHT CURTAIN AND SENSORS ELEMENTS "ML S" Integrated	
Muting sensors – for one-way openings with pallet exit.	8
MT TRX MODELS	9
SERIES "MT" - KIT PREASSEMBLED OF MI/ML/MT TRX LIGHT CURTAIN AND SENSORS ELEMENTS "MT S" Integrated	
Muting sensors – for two-way openings with pallet entrance/exit.	9
POSITIONING	10
POSITIONING OF THE MUTING SENSORS ("MI" SERIES)	10
INSTALLATION	12
SAFETY DISTANCE CALCULATION	13
<i>VERTICAL POSITION OF THE LIGHT CURTAIN</i>	14
MULTIPLE SYSTEMS	15
<i>DISTANCE BETWEEN REFLECTING SURFACES</i>	15
ELECTRICAL CONNECTIONS	16
M23 CONNECTOR (MALE)	17
CONNECTIONS CONNECTOR M12 n. 1 (FOR MUTING SENSOR) (Female Connector)	19
CONNECTIONS CONNECTOR M12 n. 2 (FOR MUTING SENSOR) (Female Connector)	19
EXAMPLE OF CONNECTION: MI TRX WITH AD SR0 WITH start/restart interlock activated	20
EXAMPLE OF CONNECTION: MI TRX L WITH AD SR0 WITH start/restart interlock activated	20
EXAMPLE OF CONNECTION : J TRX L WITH AD SR0 WITH start/restart interlock activated	21
MOUNTING AND OPTICAL ALIGNMENT	22
LIGHT SIGNALS	23
ACTIVE ELEMENT SIGNALS	23
SELECTION OF CONFIGURATION AND OPERATING MODE	25
SELECTION FEEDBACK EXTERNAL CONTACTORS K1/K2	25
SELECTION OF MANUAL/AUTOMATIC OPERATION	25
SELECTION OF THE MAXIMUM DURATION AND TYPE OF MUTING	26
OVERRIDE CONFIGURATION	26
"SYSTEM STATUS" OUTPUT	27
"MUTING STATUS" OUTPUT	27
"MUTING ENABLE" INPUT	27
INTERCONNECTION MODULES MJB1 - MJB2 - MJB3 and MJB4	27
MUTING/OVERRIDE LAMP	27
MUTING OVERRIDE FUNCTION	28
DIMENSIONS	29
TECHNICAL CHARACTERISTICS	32
<i>CHECKOUTS AND MAINTENANCE</i>	34
<i>TROUBLESHOOTING</i>	35
<i>ACCESSORIES</i>	36
GUARANTEE	37



INTRODUCTION



This symbol indicates an important personal safety warning. Failure to comply with the warning may result in very high risks for exposed personnel.

The MI/ML/MT TRX safety light curtain is a multi-beam opto-electronic safety system of the Type 4 category of electro-sensitive devices in accordance with IEC61496-1,2 EN61496-1, for the protection of persons exposed to dangerous machines or plants.

This light curtain consists of ***an active element M TRX E/R*** (containing the emitter and the receiver) and ***a passive element TRX RR***, consisting of pre-aligned reflectors, capable of reflecting the strip of infrared light (Figure 1 and Figure 2).

2-beams models (distance 500mm), 3-beams models (distance 400mm) and 4-beams models (distance 300mm) are provided.

Furthermore J TRX L series (without muting) 2-beams models (distance 500mm), 3-beams models (distance 400mm) and 4-beams models (distance 300mm) are provided.

MI TRX is ideal for protecting:

- automatic palletizing/depalletizing systems
- materials handling and storage systems;
- packing and packaging machines;
- assembly lines;
- industrial automatic warehouses;
- AGV transit openings;
- metal, wood, marble and glass tool machines.



For problems regarding safety, if necessary, consult the competent safety authorities of your country or the related industrial association.



For applications in the food industry, consult the manufacturer to check compatibility between the materials of the light curtain and the chemical agents used.



The guarding function of opto-electronic safety devices is not effective in the case in which the machine cannot be electrically controlled and is unable to stop the dangerous movement immediately at any time during the work cycle.

PRINCIPLE OF OPERATION

Figure 1 shows the MI/ML/MT TRX way of operation :

The active element **M TRX E/R** contains the emitter and the receiver units; the emitted infrared beam, correctly reflected by the pre-aligned deflection mirrors of the passive element **TRX RR**, is received by the receiver of the M TRX E/R.

With the protected area clear, the two PNP outputs of the active elements are in ON condition (24VDC) and guarantee the normal operation of the connected machine.

When an object interrupts the infrared beams, the TRX PNP outputs are de-energized (OFF condition - 0VDC). This condition permits to stop the moving body of the machine (thanks to a specific stopping circuit).

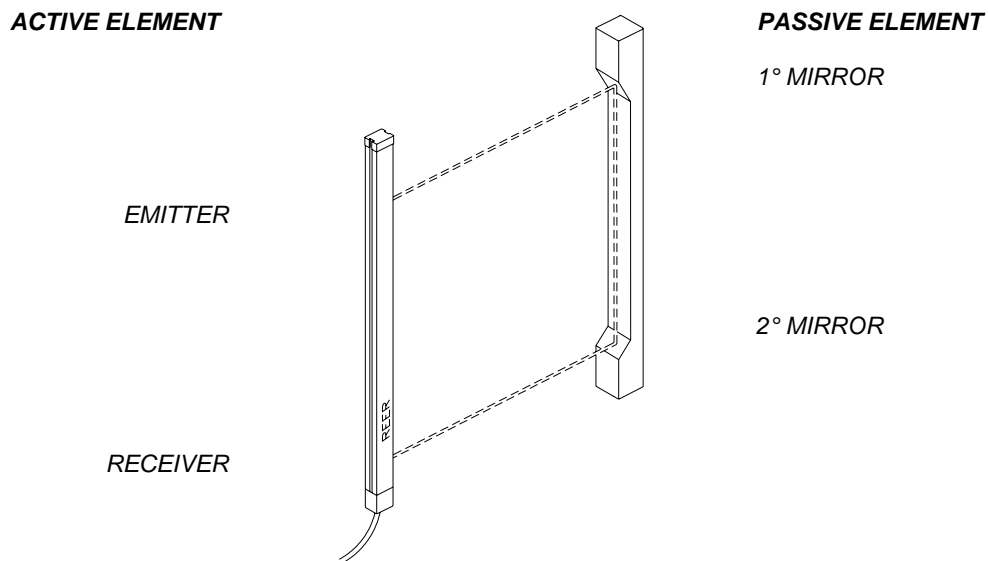

Figure 1 - MI TRX / J TRX with 2 beams

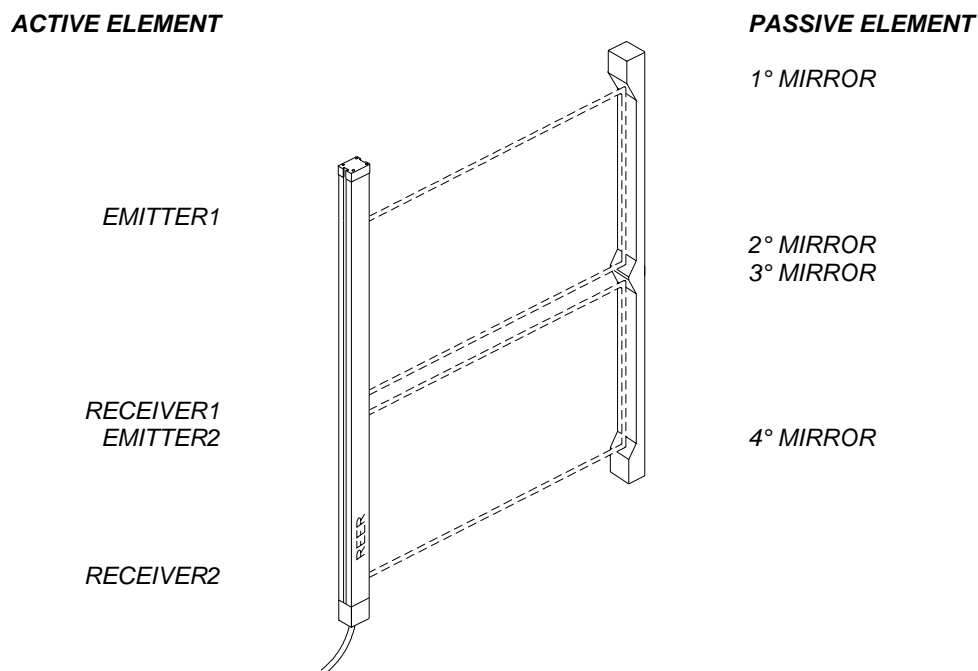

Figure 2 - MI TRX / J TRX with 3 beams

ACTIVE ELEMENT

PASSIVE ELEMENT

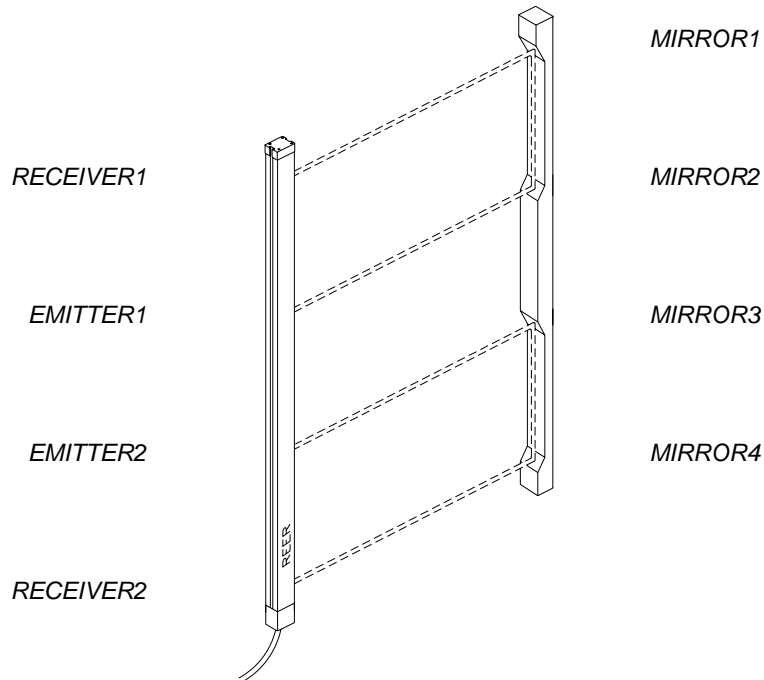

Figure 3 - MI TRX / J TRX con 4 raggi

MUTING FUNCTION



The Muting function is a temporary suspension of the safety light curtain's protective function. Carefully check your risk analysis in order to assess whether the Muting function is compatible with your application and what additional measures have to be taken.

The Muting function generates a **temporary, automatic interruption of safety light curtain operation** in order to permit normal transit of material through the guarded opening.



The Muting function is activated when the system detects the object that interrupts the opening protected. In other words, when the system recognizes the material and distinguishes between this and any operator (in a potentially dangerous situation), it is enabled to bypass the light curtain temporarily, allowing the material to pass through the opening.

The Muting sensors – which can be integrated in the light curtain (**models "ML" and "MT"**) or be external (**model "MI"**) – form the sensing system that decides whether the Muting function is to be activated (or not). Control of the dangerous opening can be de-activated only by a correct sequence of interruption of the beams of the Muting sensors.

The TRX system is available in the models "ML" and "MT" (with 2 and 4 integrated optoelectronic sensors) and "MI" that can be collected with 2 or 4 external sensors of various kinds (proximity, optical, capacity etc.).

The Muting function is activated by the contemporary occurrence of two events :

- Activation of the Muting sensors.
- Signal MUTING ENABLE (pin 15 of the connector M23) low level (0VDC).

-  **Remember that muting is a temporary automatic suspension of the safety function. This means that a time limit is always mandatory. If a time out limit of 90min is a too short time for a particular machine cycle, the configuration without time monitoring ($t = \infty$) can be selected.**
-  **When time out $t = \infty$ is selected, additional controls shall be implemented to detect an erroneous muting activation caused by : safety system accumulation of faults or muting sensors activated all the time. For example for the application of guarding the openings of a conveyor system (palletizers) it is necessary to monitor the system signals to verify if the pallet is permanently in the detection zone.**
-  **Carry out a specific risk analysis of the application if no muting time out ($t = \infty$) is selected.**

MODELS MI TRX

MI TRX can use 2 or 4 muting sensors that should be connected to the M12 connectors positioned on the front of the active element MI TRX E/R. These sensors can be of various kinds (proximity, optical, capacity) with a PNP type OUTPUT or electromechanical and with commutation DARK-ON (therefore an active OUTPUT in the presence of material). In order to connect 4 sensors, one of the following operation modes can be used:

1) Contemporary; 2) Sequential

CONNECTION WITH 2 EXTERNAL SENSORS

This model is two-way and is useful for protecting pallet entrance/exit openings.

-  **The point of intersection of the two sensors must be located inside the dangerous area to prevent accidental and dangerous activation of the Muting function.**

The Muting function is activated following concurrent interruption (within max. 4s) of sensors S1 and S2. The Muting function continues as long as both sensors are occupied. When the first of the two sensors is cleared, the Muting function is disabled.

Also for this model, the maximum duration of the Muting condition (timeout) can be set to 30 seconds or 90 minutes.

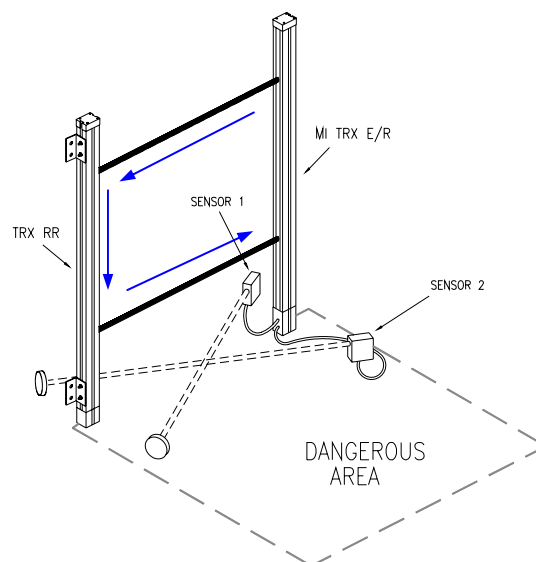

Figure 4 - connection with 2 external sensors

MI MODELS USED WITH "L" OPERATIONAL LOGIC

In this model the sensors 1 and 2 are on the same side with respect to the vertical curtain and are positioned in front of the dangerous opening (Figure 5 and Figure 6). This model is unidirectional and is useful for protecting openings with pallet exit.

The activation of the Muting function takes place following the simultaneous interruption (within max. 4 sec) of sensors S1 and S2. The Muting function remains while both sensors are occupied.

On release of the first of the 2 sensors, the material will still have 4 seconds available to abandon the protected area delimited by the curtain. The Muting condition will be disabled as soon as the protected area is released.

If the curtain is still occupied after the 4 seconds, the OSSD outputs are disabled, interrupting machine operation.

For this model, the maximum duration of the Muting condition (timeout) can be selected in 30 seconds or 90 minutes (Table 10).



It is indispensable that a Muting sequence is completed (release of controlled area) in order to guarantee the correct activation of the successive sequence.



For safe operation of the MI series (with L logic), it is necessary that the muting sensors are positioned inside the dangerous area (traced in Figure 5 and Figure 6).

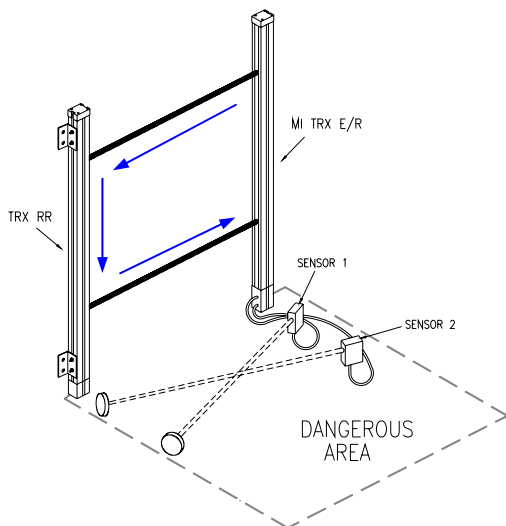

Figure 5 - Crossed sensors

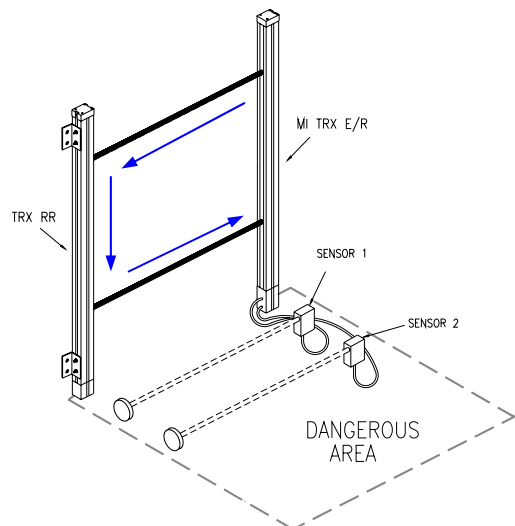

Figure 6 - Parallel sensors

CONNECTION WITH 4 EXTERNAL SENSORS

Using 4 sensors, two methods of operation are possible:

Sequential

The Muting function is activated following sequential interruption of sensors S1 and S2 and of sensors S3 and S4. **It is important to remember that, for correct actuation of the Muting function, the sequence indicated in Figure 7 and Table 1 is required (without time restrictions).**

It is also possible to enable a control of the activation time of the 4 sensors.

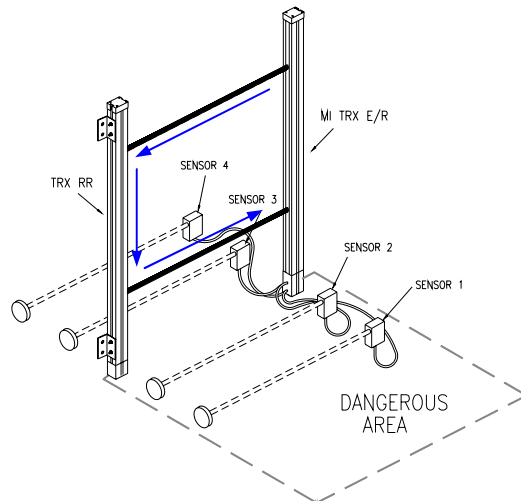

Figure 7 - Connection with 4 external sensors

SENSOR 1	SENSOR 2	SENSOR 3	SENSOR 4	LIGHT CURTAIN STATUS
0	0	0	0	LIGHT CURTAIN ACTIVE
1	0	0	0	LIGHT CURTAIN ACTIVE
1	1	0	0	MUTING
1	1	1	0	MUTING
1	1	1	1	MUTING
0	1	1	1	MUTING
0	0	1	1	MUTING
0	0	0	1	LIGHT CURTAIN ACTIVE
0	0	0	0	LIGHT CURTAIN ACTIVE

Table 1 - Sequential

LEGEND: 0 = SENSOR FREE; 1 = SENSOR ENGAGED

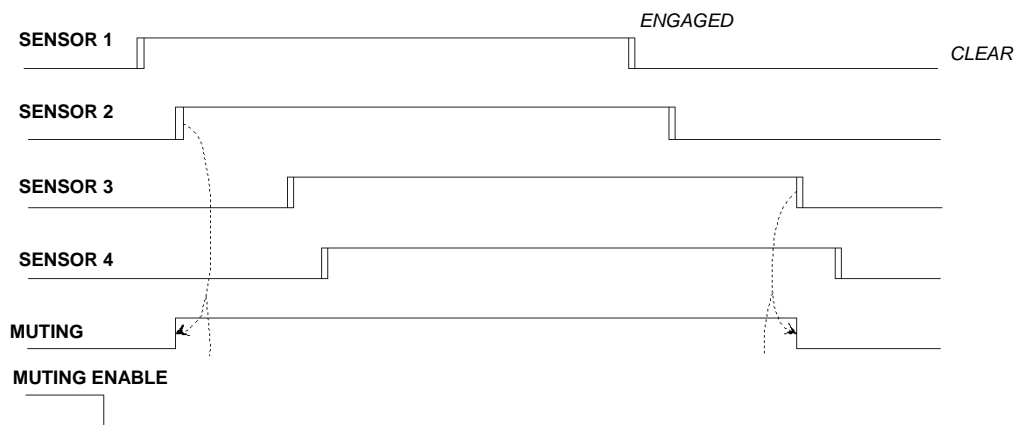

Figure 8: Sequential muting: activation sequence

Concurrent

The Muting function is activated following concurrent interruption (within maximum 4 sec) of sensors S1 and S2 and then S3 and S4.

Muting status ends after clearing of the opening and of one of S3 or S4 (S1 or S2 with material transiting in the opposite direction).

➔ The MI models connected with 4 external sensors, have two available timeouts: 1) 30 sec; 2) infinite.

MODELS MI TRX L

MI TRX L only uses 2 external sensors that can be connected to the main connector M23 placed on the active element MI TRX L E/R. These sensors can be of various kinds (proximity, optical, capacity) with a PNP type OUTPUT or electromechanical and with commutation DARK-ON (therefore an active OUTPUT in the presence of material).

In order to learn more about operation and the connection layout of this model, refer to the paragraph "CONNECTIONS WITH 2 EXTERNAL SENSORS" on page 5.

ML TRX MODELS

SERIES "ML" - KIT PREASSEMBLED OF MI/ML/MT TRX LIGHT CURTAIN AND SENSORS ELEMENTS "ML S" Integrated Muting sensors – for one-way openings with pallet exit.

In this model, the sensors 1 and 2 are on the same side of the vertical light curtain and are placed in front of the guarded opening (Figure 9).

This model is one-way and is useful for protecting pallet exit openings.

The Muting function is activated following concurrent interruption (within max. 4 sec) of sensors S1 and S2. The Muting function remains active as long as both sensors remain occupied.

When the first of the 2 sensors is cleared, the material has four seconds to abandon the guarded area delimited by the light curtain. The Muting condition will be disabled as soon as the protected area is cleared.

After 4 seconds, if the light curtain is still occupied, the OSSD outputs are disabled, interrupting operation of the machine. For this model, the maximum duration of the Muting condition (timeout) can be set to 30 seconds or 90 minutes.

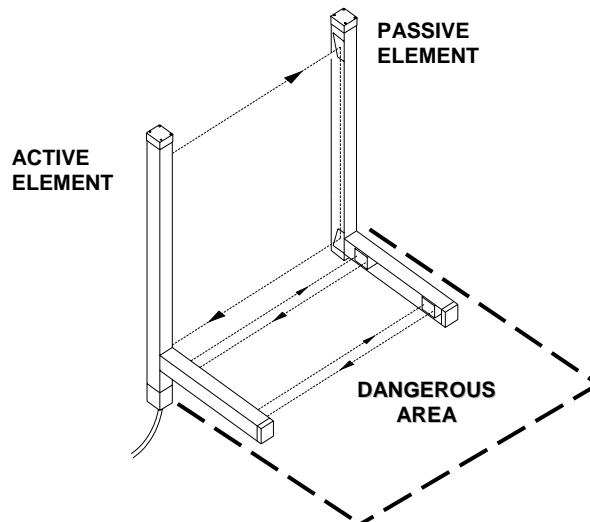



Figure 9

-  **To guarantee the safety operation of the ML series, the horizontal muting sensor must be mounted *INSIDE* the dangerous area (dashed in Figure 9).**
-  **When using a ML TRX series light curtain, the minimum distance between two consecutive pallet must be 40cm (47cm for ML TRX V models).**

MT TRX MODELS

SERIES "MT" - KIT PREASSEMBLED OF MI/ML/MT TRX LIGHT CURTAIN AND SENSORS ELEMENTS "MT S" Integrated Muting sensors – for two-way openings with pallet entrance/exit.

This model is two-way and is useful for protecting pallet entrance/exit openings (Figure 10).
Using this model, two methods of operation are possible:

Concurrent

The Muting function is activated following concurrent interruption (within maximum 4 sec) of sensors S1 and S2 and then S3 and S4.

Muting status ends after clearing of the opening and of S3 (S2 with material transiting in the opposite direction).

Sequential

The Muting function is activated following sequential interruption of sensors S1 and S2, of the opening and of sensors S3 and S4. **It is important to remember that, for correct actuation of the Muting function, the sequence indicated in Figure 8 and Table 1 is required (without time restrictions).**



The MT TRX models have two available timeouts: 1) 30 sec; 2) infinite (Sequential operation only).



The pallet minimum length (in both operation modes) must be 75cm (89cm for MT TRX V models) all the 4 sensors have to be simultaneously occupied.

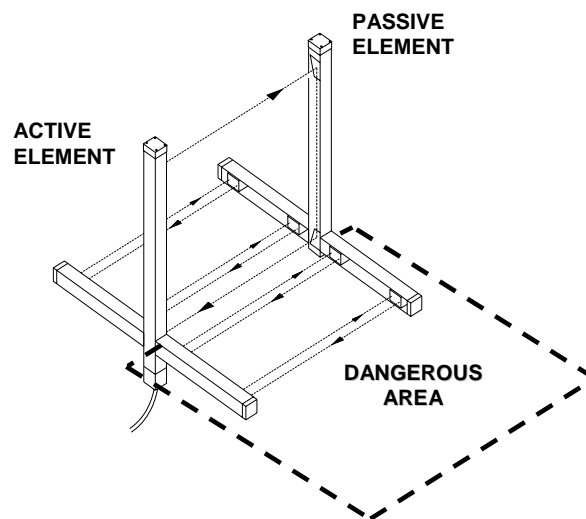

Figure 10

POSITIONING

Protection of the guarded opening by MI/ML/MT TRX must be integrated with suitable mechanical guards. While the "MI" model permits various types of installation (2, 4 sensors, one- or two-way), the "ML" and "MT" have been designed for "dedicated" use.

- In particular, "ML" manages the muting function in **one-way** mode (for pallet exit); in this case, the horizontal arms must be positioned between the dangerous area and the light curtain.
- The "MT" model manages the muting function in **two-way** mode using four horizontal arms. This model is useful when the pallets, once the process has been carried out by the dangerous machine, must be returned outside using the same palletizer.

POSITIONING OF THE MUTING SENSORS ("MI" SERIES).

2 sensors

The Active and Passive elements of the light curtain must be positioned so as to permit access to the dangerous area from above, from below and from the sides without first of all intercepting at least one of the optical beams.

Indications for correct positioning of the light curtain are provided in the figure below.

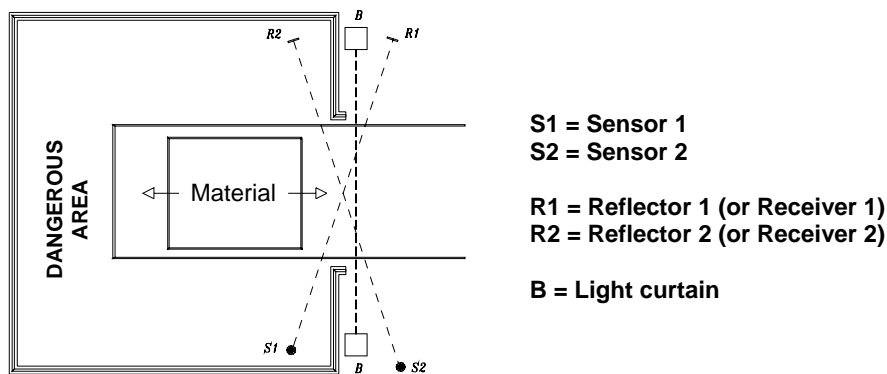

Figure 11

For correct positioning of sensors 1 and 2, i.e. those that manage enabling and disabling of the Muting function, take into account the following:

- the two beams must be crossed and pass diagonally through the zone guarded by the light curtain;
- the point of intersection of the two beams must be in the dangerous area beyond the light curtain;
- the angle between the two Muting beams must be calculated according to the size of the pallet and its speed, taking into account that the Muting function is activated only if the interception delay between the two sensors is less than 4 seconds;
- the pallet must interrupt the two beams before intercepting the light curtain;
- the two beams must be interrupted continuously by the pallet for the entire period during which the pallet passes between the sensors;
- make sure that the two beams are effectively intercepted by the material on the pallet and not by the empty pallet;
- the zone identified by the points of interception and clearing of the beams of sensors 1 and 2 by pallet must be limited as far as possible (or suitably protected) so as to avoid the possibility of accidental passing through the light curtain with Muting active (Figure 12).

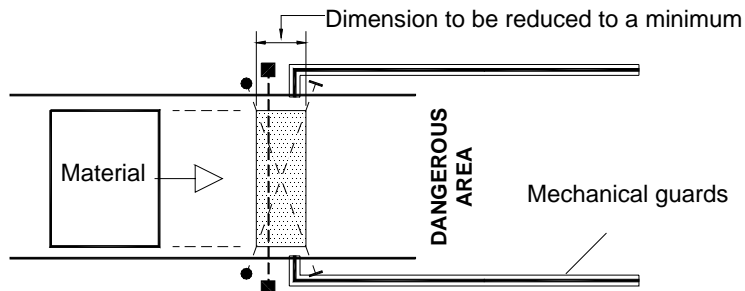

Figure 12

4 sensors

For correct positioning of sensors 1, 2, 3 and 4, i.e. those that manage enabling and disabling of the Muting function, take into account the following:

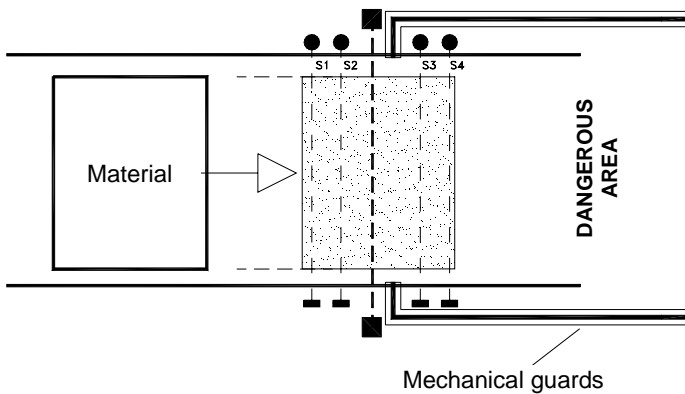

Figure 13

SEQUENTIAL (Figure 13):

- the distance between the first and the last sensor must never exceed the length of the pallet (**in one of the phases of the sequence, the 4 sensors must all be intercepted simultaneously**);
- the pallet must interrupt sensors S1 and S2 (or S4 and S3 in the opposite direction) **before** intercepting the light curtain;
- make sure that the two beams are intercepted by the material on the pallet and not by the empty pallet

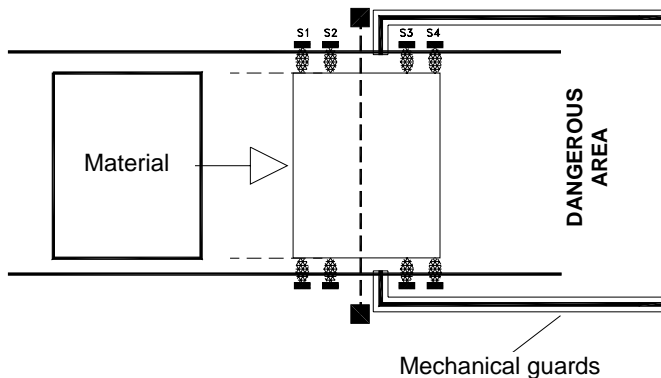







Figure 14

CONCURRENT (Figure 14):

- The Muting function is activated following concurrent interruption (**within max. 4 sec**) of sensors **S1 and S2 (or S4 and S3 in the opposite direction)**.
- also in this operating mode, for correct activation of the Muting function, **for a short period of time, all 4 sensors must be intercepted simultaneously**.

INSTALLATION



Before installing the TRX safety system, make sure that:

-  **The safety system is only used as a stopping device and not as a machine control device.**
-  **The machine control can be actuated electrically.**
-  **All dangerous machine movements can be interrupted immediately. In particular, the machine stopping times must be known and, if necessary, measured.**
-  **The machine does not generate dangerous situations due to materials projecting or falling from overhead; if that is not the case, additional mechanical guards must be installed.**
-  **The minimum dimensions of the object that must be intercepted are greater than or equal to the resolution of the TRX.**

Knowledge of the shape and dimensions of the dangerous area enables the width and height of the relative access area to be calculated.

-  **Compare these dimensions with the maximum working range and the height of the protected area in relation to the TRX.**

The general instructions set out below must be taken into consideration before placing the safety device in position.

-  **Make sure that the temperature of the environment in which the system is to be installed is compatible with the temperature parameters contained in the technical data sheet.**
-  **Do not install the active unit close to bright or high-intensity flashing light sources.**
-  **Certain environmental conditions may affect the monitoring capacity of the photoelectric devices. In order to assure correct operation of equipment in places that may be subject to fog, rain, smoke or dust, the appropriate correction factors Cf should be applied to the maximum working range values. In these cases:**



$$Pu = Pm \times Cf$$

where Pu and Pm are, respectively, the working and maximum range in meters.

The recommended Cf factors are shown in the table below:

ENVIRONMENTAL CONDITION	CORRECTION FACTOR Cf
Fog	0.25
Steam	0.50
Dust	0.50
Dense fumes	0.25

Table 2

-  **If the device is installed in areas liable to sudden changes in temperature, suitable measures must be taken in order to avoid formation of condensation on the lenses which could impair detection efficiency.**
-  **If TRX light curtains are used with palletizers, depalletizers and stacking/destacking machines for empty pallets, refer to European standard EN 415-4.**

SAFETY DISTANCE CALCULATION



The light curtain must be installed at a distance that is greater than or equal to the **minimum safety distance S**, so that a dangerous point can only be reached after all hazardous machine movements have stopped (Figure 15).

According to European standard EN999, the minimum safety distance **S** must be calculated using the following formula:

$$S = K (t_1 + t_2) + C$$

with:

S	<i>minimum safety distance</i>	mm
K	<i>approach speed of object to the dangerous area</i>	mm/sec
t₁	<i>response time of the safety light curtain in seconds</i>	sec
t₂	<i>machine response time, in seconds, meaning the time required for the machine to interrupt the dangerous movement following transmission of the stop signal</i>	sec
c	<i>Additional distance based on the possibility of introducing the body or part of the body into the dangerous area before activating the protection device</i>	mm

-  **The non-observance of the correct safety distance reduces or cancels the protective action of the light curtain.**
-  **If the position of the light curtain does not prevent the operator from having access to the dangerous area without being detected, additional mechanical guards must be installed to complete the system.**

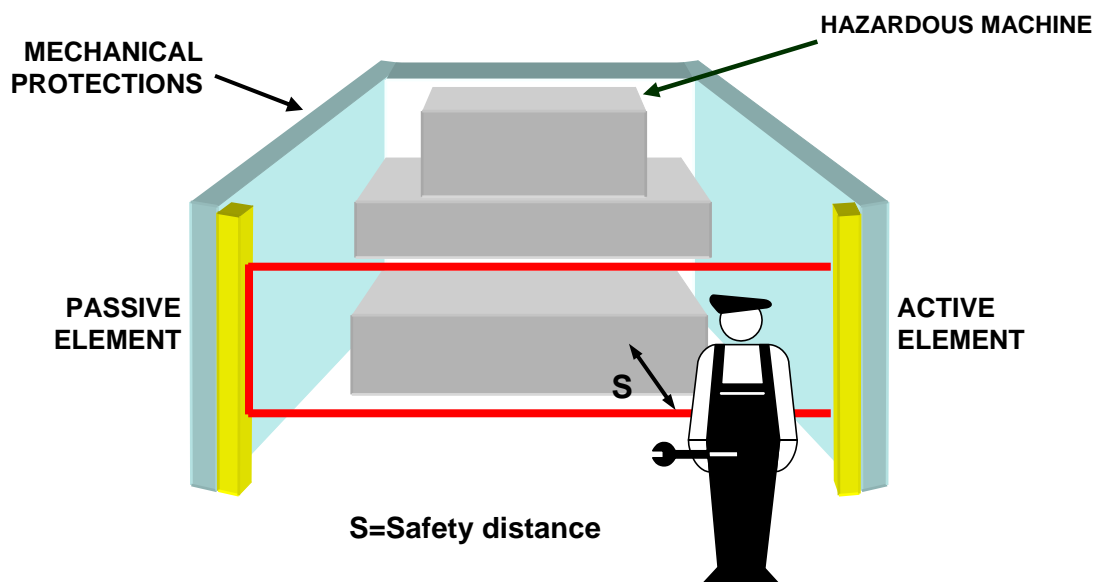

Figure 15

VERTICAL POSITION OF THE LIGHT CURTAIN

These models are suitable for the protection of the entire body and must not be used to protect arms or legs.

The minimum safety distance **S** is calculated according to the following formula:

$$S = 1600 (t_1 + t_2) + 850$$

→ The recommended height **H** from the reference surface **G** (ground) is as follows:

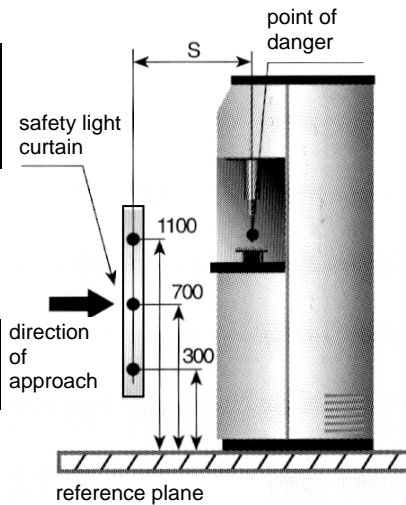

Figure 16

MODEL	BEAMS	Reccomended Height H (mm)
TRX E/R	2	400 – 900
TRX E/R	3	300 – 700 – 1100
TRX E/R	4	300 – 600 – 900 - 1200

For applications on packaging machines (palletizers and depalletizers), comply with the indications of European standard EN 415-4, which are repeated below.

Dimensions in m

Type of access

**From low level (floor)
Device with minimum 3 beams**

**Above the conveyor (roller bed)
Device with minimum 2 beams**

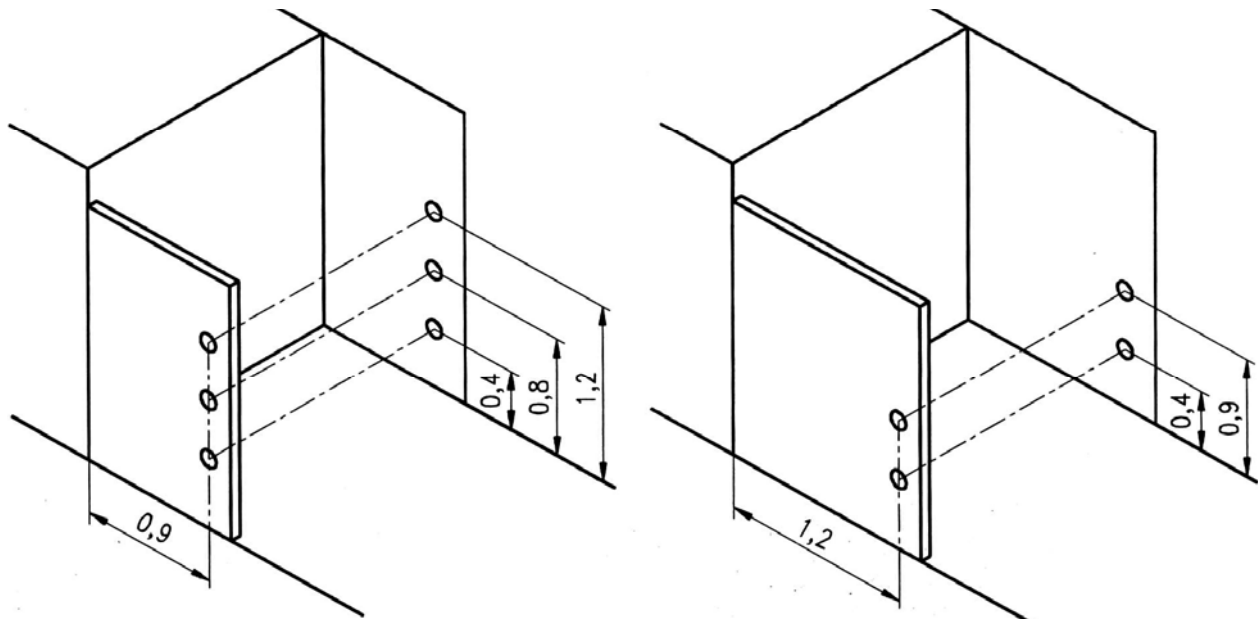
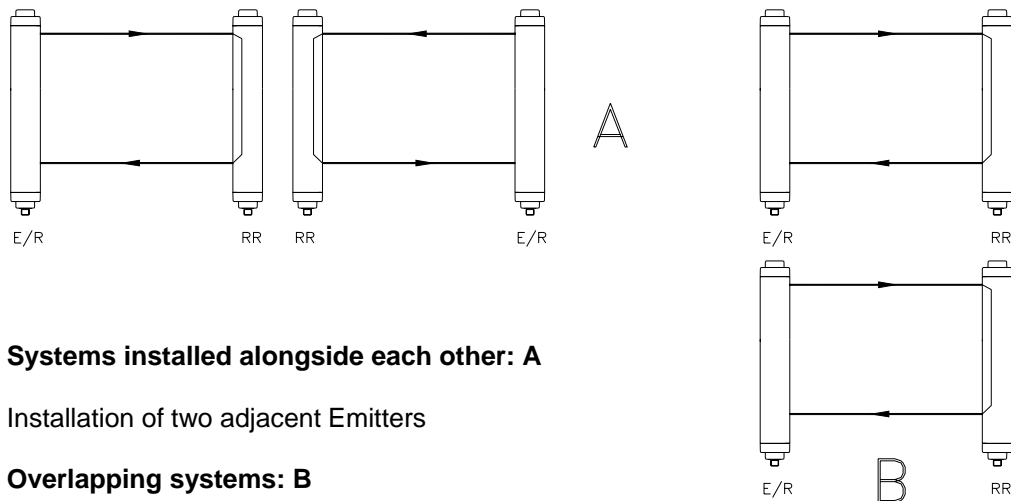

Figure 17: Protection of the opening with MI/ML/MT TRX light curtain and mechanical side guards.

MULTIPLE SYSTEMS

When several TRX systems are used, these must not interfere optically with each other. Position the elements so that the beam emitted by the Emitter of a system is received only by the respective Receiver (see page 3).

Figure 18 provides various examples of correct positioning of two photo-electric systems. Incorrect positioning could generate interference and possibly result in irregular operation.



Systems installed alongside each other: A

Installation of two adjacent Emitters

Overlapping systems: B

Figure 18



For the MT/ML models take special area in order to avoid optical interference by the muting sensors in the arms. (For example mechanical protection).

DISTANCE BETWEEN REFLECTING SURFACES

The presence of reflecting surfaces in proximity of the photoelectric light curtain may generate spurious reflections that prevent monitoring. With reference to Figure 19, object **A** is not detected because surface **S** reflects the beam and closes the optical path between the active and passive elements.

A minimum distance **d** must therefore be maintained between any reflecting surfaces and the protected area. The minimum distance **d** must be calculated according to the distance **l** between the active and passive unit, considering that the angle of projection and reception is 4°.

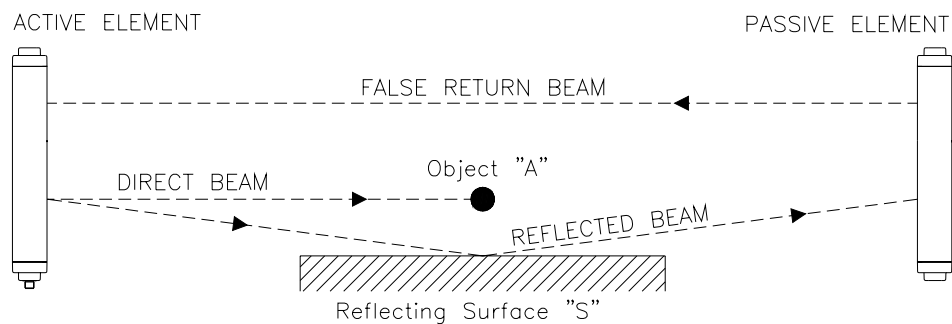

Figure 19

Figure 20 illustrates the values for the minimum distance **d** that must be maintained when the distance **l** between the active and passive elements is changed.

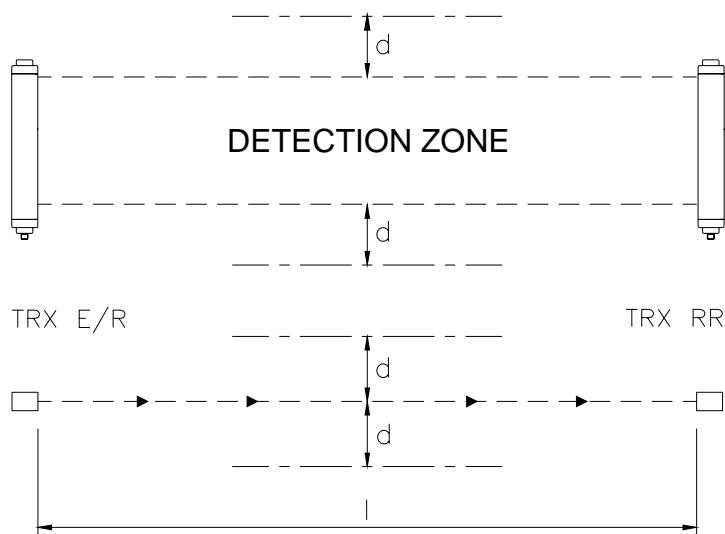
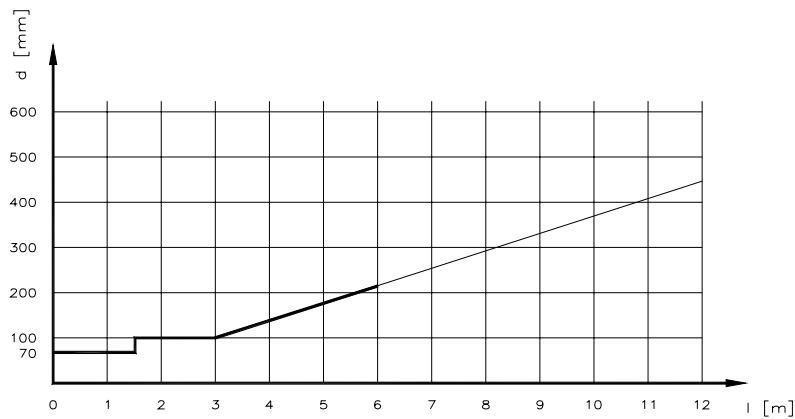

Figure 20

After installing the system, check whether any reflecting surfaces intercept the beams, first in the centre and then in the vicinity of the active unit.

During these operations, the red LED on the active elements should never, for any reason, switch off.

ELECTRICAL CONNECTIONS

WARNINGS

Before making the electrical connections, make sure that the supply voltage complies with the one specified in the technical data sheet.



MI/ML/MT TRX must be supplied with 24Vdc±20% power supply that guarantee safe isolation from main voltage (PELV).



The external power supply must comply with the standard EN 60204-1 (Chapter 6.4).

The electrical connections must be made according to the diagrams in this manual. In particular, do not connect other devices to the connectors of the active unit.

To guarantee reliability of operation, when using a diode jumper supply unit, its output capacity must be at least 2000µF for each absorbed **A**.

M23 CONNECTOR (MALE)

JANUS MI TRX
JANUS ML TRX
JANUS MT TRX

JANUS MI TRX L
JANUS J TRX L

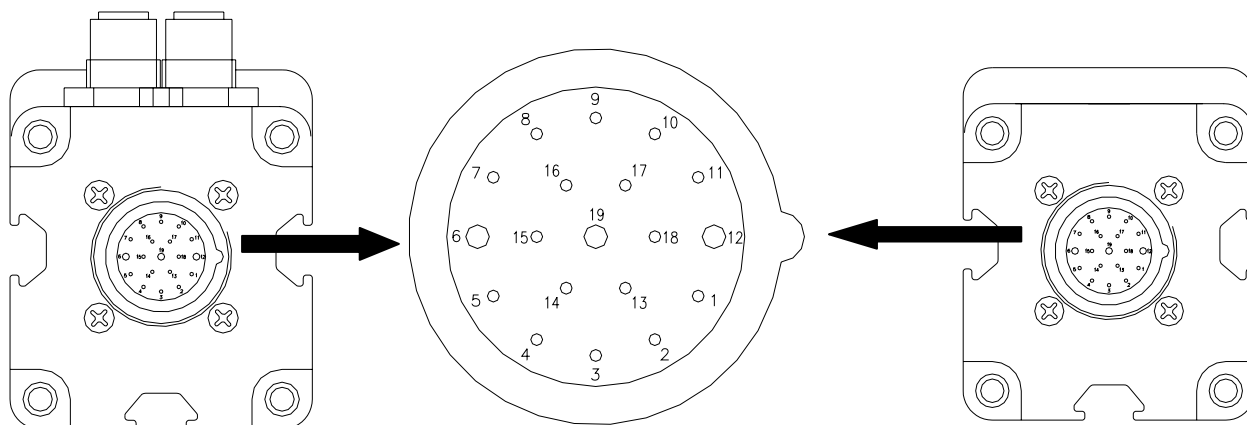

MI TRX / ML TRX / MT TRX					
PIN	COLOUR	NAME	TYPE	DESCRIPTION	OPERATION
1	White	MUTING LAMP	OUT	Muting lamp OUTPUT	24VDC with Muting or Override active
2	Red	OSSD2	OUT	Safety outputs	24VDC with: <ul style="list-style-type: none"> Free light curtain Muting active Override Muting
3	Grey	OSSD1	OUT		
4	Yellow	SYSTEM STATUS	OUT	OSSD status	24VDC with active outputs
5	Green	MUTING STATUS	OUT	Condition of the muting function	24VDC with active Muting
6	Blue	0VDC		Power 0Vdc	-
7	Purple	CONF0	IN	Configuration of Muting characteristics	Table 10
8	Pink	CONF1	IN		
9	Grey-Pink	CONF2	IN		
10	Red-Blue	CONF3	IN	Configuration of the Muting characteristics	Table 10
11	White-Green	ENABLE_K	IN	Enablement control of external meters	Table 8
12	Black	PE	-	Earth connections	-
13	White-Yellow	MAN/AUTO	IN	Selection mode Manual/Automatic	Table 9
14	Yellow-Brown	RESTART	IN	Restart	Active on the transition LO-HI (minimum duration of the signal 400 msec)
15	White-Grey	MUTING ENABLE	IN	Enablement INPUT Muting	Active low
16	Grey-Brown	OVERRIDE1	IN	Override signals	Table 11
17	White-Pink	OVERRIDE2	IN		
18	Brown-Green	FEED_K1K2	IN	Feedback of external meters	Table 8
19	Brown	24VDC		Power 24Vdc	

Table 3

MI TRX L					
PIN	COLOUR	NAME	TYPE	DESCRIPTION	OPERATION
1	White	MUTING LAMP	OUT	Muting lamp OUTPUT	24VDC with Muting or Override active
2	Red	OSSD2	OUT	Safety outputs	24VDC with: <ul style="list-style-type: none"> Free light curtain Muting active Override Muting
3	Grey	OSSD1	OUT		
4	Yellow	SYSTEM STATUS	OUT	OSSD status	24VDC with active outputs
5	Green	MUTING STATUS	OUT	Condition of the muting function	24VDC with active Muting
6	Blue	0VDC		Power 0Vdc	-
7	Purple	SENS1	IN	Input SENSOR1	< 5VDC : free sensor 11±30 VDC : busy sensor
8	Pink	SENS2	IN	Input SENSOR2	
9	Grey-Pink	CONF2	IN	Configuration of the Muting characteristics	Table 10
10	Red-Blue	CONF3	IN		
11	White-Green	ENABLE_K	IN	Enablement control of external meters	Table 8
12	Black	PE	-	Earth connections	-
13	White-Yellow	MAN/AUTO	IN	Selection mode Manual/Automatic	Table 9
14	Yellow-Brown	RESTART	IN	Restart	Active on the transition LO-HI (minimum duration of the signal 400 msec)
15	White-Grey	MUTING ENABLE	IN	Enablement INPUT Muting	Active low
16	Grey-Brown	OVERRIDE1	IN	Override signals	Table 11
17	White-Pink	OVERRIDE2	IN		
18	Brown-Green	FEED_K1K2	IN	Feedback of external meters	Table 8
19	Brown	24VDC		Power 24Vdc	

Table 4

J TRX L					
PIN	COLOUR	NAME	TYPE	DESCRIPTION	OPERATION
1	White	-			
2	Red	OSSD2	OUT	Safety outputs	24VDC with: <ul style="list-style-type: none"> Free light curtain Muting active Override Muting
3	Grey	OSSD1	OUT		
4	Yellow	SYSTEM STATUS	OUT	OSSD status	24VDC with active outputs
5	Green				
6	Blue	0VDC		Power 0Vdc	-
7	Purple	-			
8	Pink	-			
9	Grey-Pink	-			
10	Red-Blue	-			
11	White-Green	ENABLE_K	IN	Enablement control of external meters	Table 8
12	Black	PE	-	Earth connections	-
13	White-Yellow	MAN/AUTO	IN	Selection mode Manual/Automatic	Table 9
14	Yellow-Brown	RESTART	IN	Restart	Active on the transition LO-HI (minimum duration of the signal 400 msec)
15	White-Grey	-			
16	Grey-Brown	-			
17	White-Pink	-			
18	Brown-Green	FEED_K1K2	IN	Feedback of external meters	Table 8
19	Brown	24VDC		Power 24Vdc	

Table 5

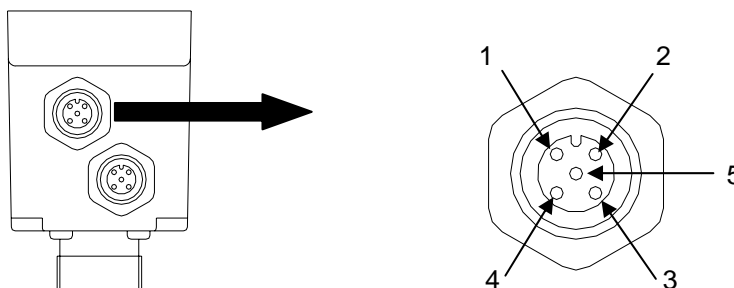
CONNECTIONS CONNECTOR M12 N. 1 (FOR MUTING SENSOR) (FEMALE CONNECTOR)

PIN	COLOR	NAME	TYPE	DESCRIPTION	OPERATION
1	Brown	24 VDC	OUT	Power supply sensors 1 and 3	Positive
2	White	SENSOR 1	IN	Input SENSOR 1	< 5VDC : SENSOR FREE 11÷30 VDC : SENSOR ACTUATED
3	Blue	0 VDC	OUT	Power supply sensors 1 and 3	Negative
4	Black	SENSOR 3	IN	Input SENSOR 3	< 5VDC : SENSOR FREE 11÷30 VDC : SENSOR ACTUATED
5	Grey	PE	-	-	-

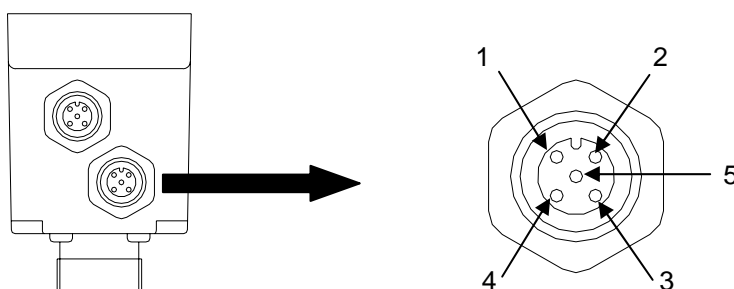
Table 6
CONNECTIONS CONNECTOR M12 N. 2 (FOR MUTING SENSOR) (FEMALE CONNECTOR)

PIN	COLOR	NAME	TYPE	DESCRIPTION	OPERATION
1	Brown	24 VDC	OUT	Power supply sensors 2 and 4	Positive
2	White	SENSOR 2	IN	Input SENSOR 2	< 5VDC : SENSOR FREE 11÷30 VDC : SENSOR ACTUATED
3	Blue	0 VDC	OUT	Power supply sensors 2 and 4	Negative
4	Black	SENSOR 4	IN	Input SENSOR 4	< 5VDC : SENSOR FREE 11÷30 VDC : SENSOR ACTUATED
5	Grey	PE	-	-	-

Table 7

➔ In the "ML" and "MT" series, the M12 connectors of the receiver must be connected only to the sensors integrated in the horizontal arms provided with the system.

EXAMPLE OF CONNECTION: MI TRX WITH AD SRO WITH START/RESTART INTERLOCK ACTIVATED

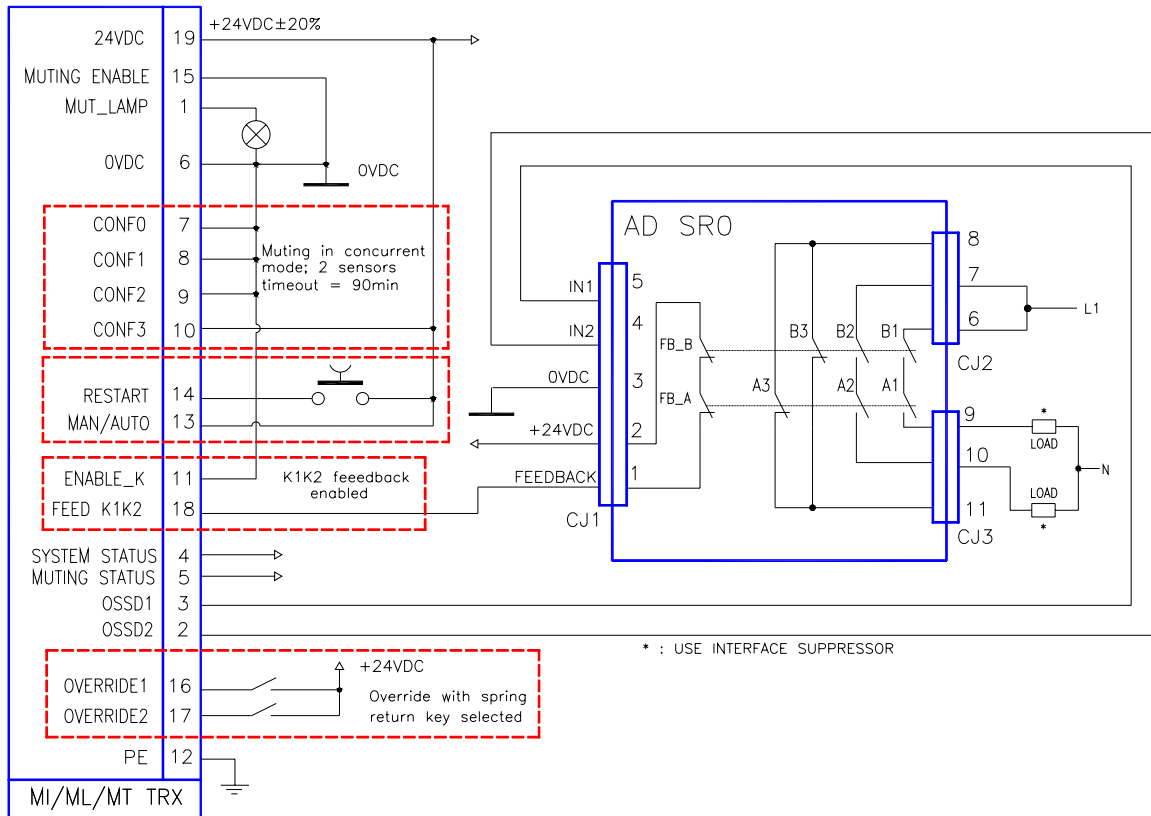

EXAMPLE OF CONNECTION: MI TRX L WITH AD SRO WITH START/RESTART INTERLOCK ACTIVATED

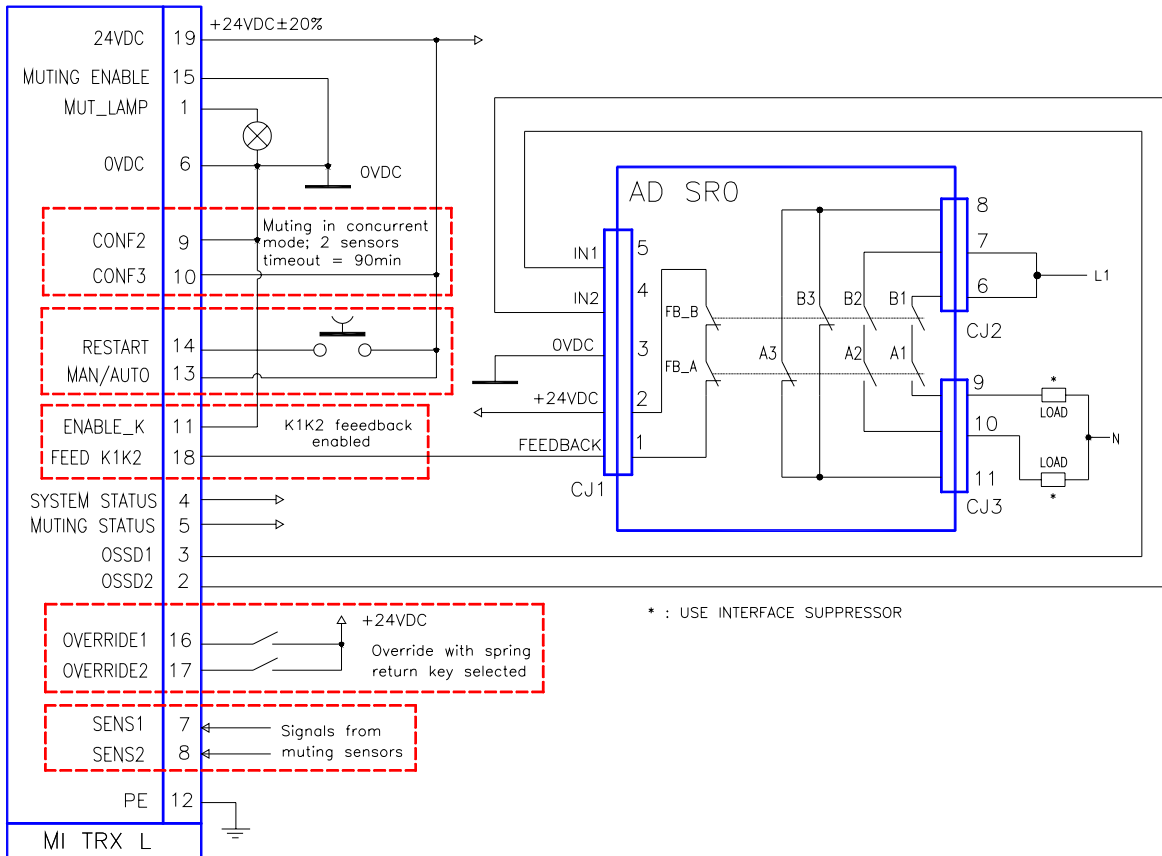

EXAMPLE OF CONNECTION : J TRX L WITH AD SR0 WITH START/RESTART INTERLOCK ACTIVATED

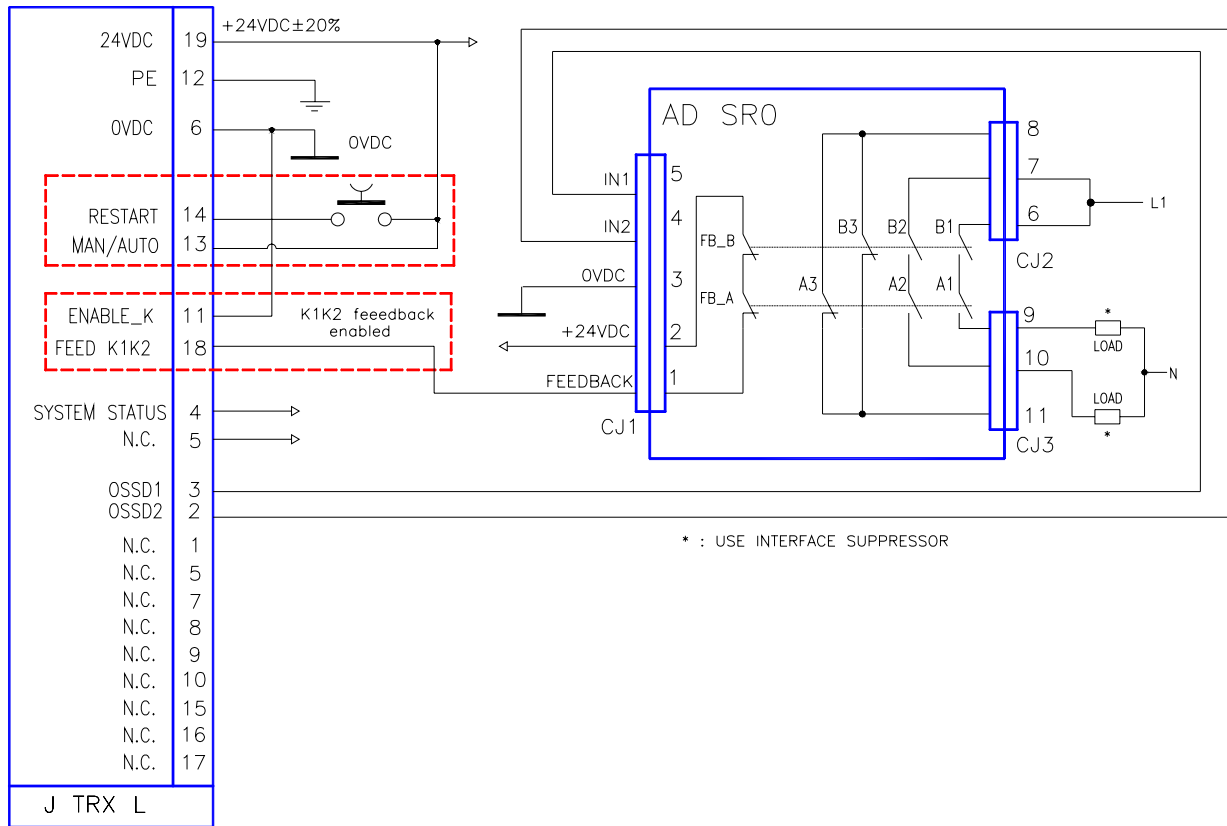

MOUNTING AND OPTICAL ALIGNMENT

The active element **TRX E/R** and the the passive element **TRX RR** must be mounted the first in front of the other with the same (or less) distance showed in the technical data.

Using the **fastening brackets and inserts** (available on request) fix the active element M TRX E/R and the passive element TRX RR aligned and parallel.

The fastening inserts can be located in the rear or in the side spline of the units, depending on the dimensions and shape of the machine rest (Figure 21).

- **MI/J MODELS:** these are supplied with one **LH** bracket, which must be fixed to the centre of both columns.
- **ML/MT MODELS:** these are supplied with two **LL** brackets (three for 3B models) which must be fixed as indicated in Figure 21.

The perfect alignment between the two units is essential for the correct light curtain operation; the control of the signal leds makes this function easier.

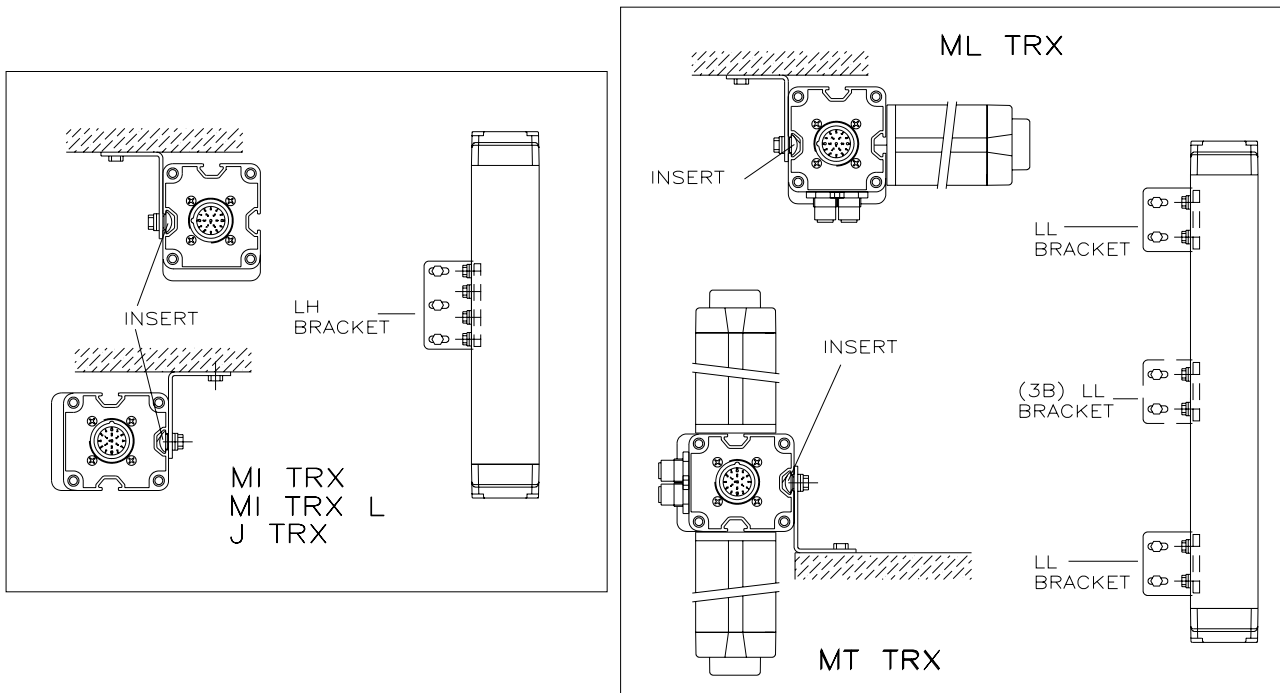

Figure 21

- Place the optical axis of the photoemitter and photoreceiver on the same axis of the reflecting mirrors of the passive element.
- Hold the passive element and move TRX E/R to find the area within which the green led stays on, then position the first beam (the one close to the indicator leds) in the centre of this area.
- Lock the two units in place.

During these operations it may be useful to check the **orange weak signal LED** on the passive element. Upon completion of alignment, this LED must be off.

If the active element is assembled in areas that are subject to strong vibrations, the use of vibration-damping supports is recommended, in order to prevent circuit malfunctions.

LIGHT SIGNALS

ACTIVE ELEMENT SIGNALS

At power-on, for a period of 5 seconds, the display will show the number "8" and all the leds will be ON. In the next 10 seconds, the display and the leds will show the configuration selected. At initial power-on after installation, always check the accuracy of these settings very carefully.

This check is also indispensable in all cases of malfunctioning (ref. "TROUBLESHOOTING").

During display of the configuration, the display will show the letter "C" while during normal operation, a hyphen "-" will be displayed.

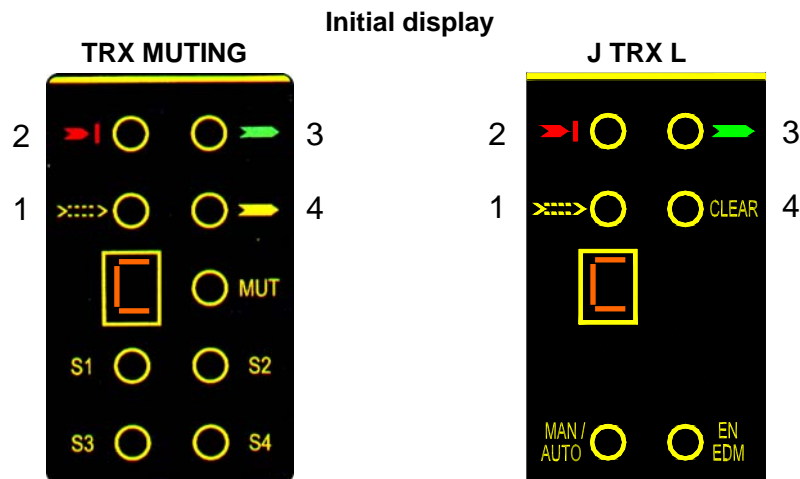

Figure 22

	LED	INITIAL CONFIGURATION		COLOR	
		(LED ON)	(LED ON)		
TRX MUTING	S1	Enabling of timeout 30s	Enabling of timeout 90min	YELLOW	
	S2	With 4 sensors, enabling of Sequential muting	With 4 sensors, enabling of concurrent op. mode	YELLOW	
	S3	Manual operation mode enabled	Automatic operation mode enabled	YELLOW	
	S4	Control of feedback external relays enabled	Control of feedback external relays disabled	YELLOW	
	MUT	Muting configuration with 4 sensors	Muting configuration with 2 sensors	YELLOW	
	Weak (1)	>:~::~:>	-	-	ORANGE
	Break (2)	>	OSSD outputs set to OFF	-	RED
	Guard (3)	>	-	-	GREEN
	Clear/Override (4)	>	Push button override	Spring return key override	YELLOW
	J TRX L	Weak (1)	>:~::~:>	-	-
Break (2)		>	OSSD outputs set to OFF	-	RED
Guard (3)		>	-	-	GREEN
Clear (4)		CLEAR	-	-	YELLOW
MAN/AUTO			Manual functioning mode enabled	Automatic functioning mode enabled	YELLOW
EN EDM			Control of feedback external relays enabled	Control of feedback external relays disabled	YELLOW



The flashing led together with the C and F letters indicates the incorrect type of configuration.

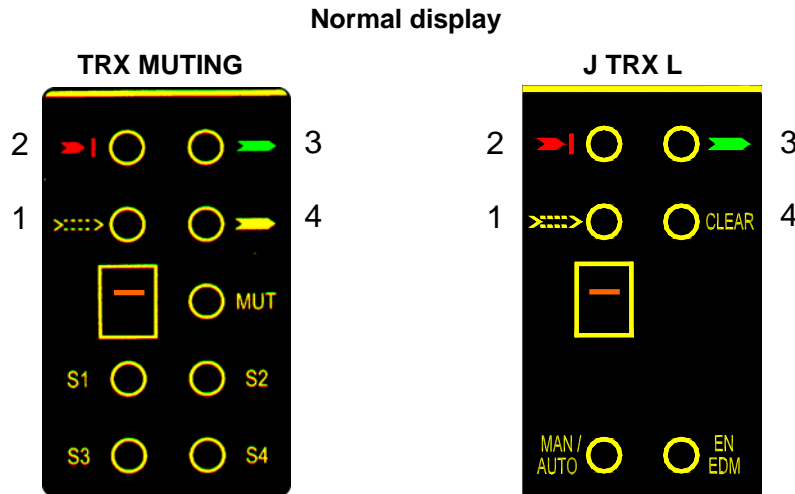

Figure 23

	LED	NORMAL OPERATION		COLOR	
		(LED ON)	(LED OFF)		
TRX MUTING	S1	Interruption Sensor 1	Sensor 1 clear	YELLOW	
	S2	Interruption Sensor 2	Sensor 2 clear	YELLOW	
	S3	Interruption Sensor 3 *	Sensor 3 clear	YELLOW	
	S4	Interruption Sensor 4 *	Sensor 4 clear	YELLOW	
	MUT	Muting active **	Light curtain active	YELLOW	
	Weak (1)		Weak signal received	Signal received OK	ORANGE
	Break (2)		Light curtain occupied, OSSD outputs set OFF	-	RED
	Guard (3)		Light curtain clear, OSSD outputs set ON	-	GREEN
	Override_1 (3)		Light curtain in override, OSSD outputs set ON ***	-	
	Clear (4)		Light curtain clear, OSSD outputs set OFF (the receiver is waiting for a Restart signal)	-	YELLOW
Override_2 (4)		Override request (BLINKING LED)	-		

* Indications not present on the model **MI TRX L**.

** The Muting/Override external lamp lights on.

*** A small "o" letter appears on the display and at the same time the Muting/Override external lamp blinks.

J TRX L	Weak (1)		Weak signal received	Signal received OK	ORANGE
	Break (2)		Light curtain occupied, OSSD outputs set OFF	-	RED
	Guard (3)		Light curtain clear, OSSD outputs set ON	-	GREEN
	Clear (4)	CLEAR	Light curtain clear, OSSD outputs set OFF (the receiver is waiting for a Restart signal)	-	YELLOW



In case of fault, only the red led will remain ON and the display will show a flashing "C" or "F" followed by the fault code (ref. TROUBLESHOOTING paragraph).

SELECTION OF CONFIGURATION AND OPERATING MODE

The inputs of the MI/ML/MT TRX light curtain make it possible to configure various operating modes. At power-on, for correct operation, the various inputs must be connected as indicated below.

SELECTION FEEDBACK EXTERNAL CONTACTORS K1/K2

Feedback of the external contactors K1/K2 is enabled at system power-on (as indicated in Table 8). If this function is enabled, the set of N.C. contacts of the external relays must be connected to pin 18 of the receiver. The voltage level of this input must be:

- +24VDC with OSSD static outputs de-activated.
- 0VDC with OSSD static outputs activated.

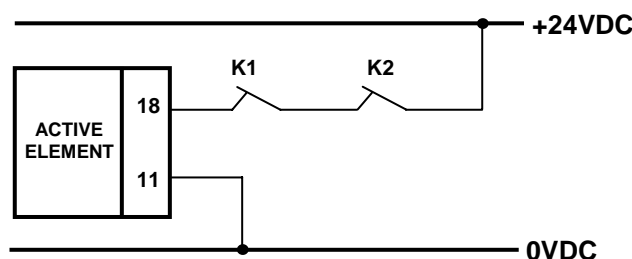

CONTROL OF EXTERNAL CONTACTORS K1/K2	Receiver pins		MEANING
	PIN 11	PIN 18	
	24VDC	0	Control disabled
	0		Control enabled
	0	0	Not permitted
	24VDC	24VDC	Not permitted

Table 8

SELECTION OF MANUAL/AUTOMATIC OPERATION

Manual or automatic operating mode can be set through connection of pins 13 and 14 of the M23 connector of the active element.

- In AUTOMATIC operation, the two static outputs OSSD1 and OSSD2 follow the status of the guarded opening. With the area guarded clear, the outputs will supply +24VDC, while with the area occupied they will supply 0VDC. Refer to Table 8 and Table 9 for correct configuration of operating mode.
- In MANUAL operation, the two static outputs OSSD1 and OSSD2 are active only with the danger area clear and after the light curtain has received a correct RESTART signal. **This command must be sent on pin 14 of the receiver and is active with a 0VDC ---> +24VDC transition.**
- The minimum duration of the RESTART command must be 100ms.

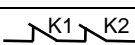
- ✘ **Use of manual mode (start/restart interlock activated) is compulsory if the safety device controls an opening to protect a danger area and a person, after passing through the opening, may remain in the danger area without being detected (use as 'trip device' according to IEC 61496). Failure to comply with this rule may result in very serious hazards for the persons exposed.**
- ✘ **The Restart control must be installed outside the danger area in a position where the danger area and the entire work area concerned are clearly visible. It must not be possible to reach the control from inside the danger area.**

SELECTION OF MANUAL/AUTOMATIC OPERATION	Active element pin		MEANING
	PIN 13	PIN 14	
	0	24VDC	Automatic
	24VDC	0	Manual
0	0	Not permitted	
24VDC	24VDC	Not permitted	

Table 9

SELECTION OF THE MAXIMUM DURATION AND TYPE OF MUTING

The inputs of the MI/ML/MT TRX light curtain active element make it possible to configure the various types of Muting available and the maximum duration of the Muting condition (timeout).

At power-on, for correct operation, the various inputs must be connected as indicated below.

Model	Selez.	Active element pin				Timeout selected	MEANING
		10 (CONF3)	9 (CONF2)	8 (CONF1)	7 (CONF0)		
MI TRX	2 sensors	0	24VDC	0	0	t1	Concurrent mode (within 4sec)
		24VDC	0	0	0	t2	
	"L" logic	0	24VDC	24VDC	24VDC	t1	
		24VDC	0	24VDC	24VDC	t2	
	4 sensors	0	0	0	24VDC	t1	Concurrent mode (within 4sec)
		0	0	24VDC	0	infinite	Sequential mode
24VDC		24VDC	0	24VDC	t1		
ML TRX	2 sensors	0	24VDC	-	-	t1	Concurrent mode (within 4sec)
		24VDC	0	-	-	t2	
	MT TRX	4 sensors	0	0	0	24VDC	t1
0			0	24VDC	0	infinite	Sequential mode
24VDC			24VDC	0	24VDC	t1	
24VDC			24VDC	24VDC	0	infinite	
MI TRX L	2 sensors	0	24VDC	-	-	t1	Concurrent mode (within 4sec)
		24VDC	0	-	-	t2	

Table 10

where: t1 = 30 sec; t2 = 90 min

OVERRIDE CONFIGURATION

Active element pin		MEANING
16 (OVERRIDE1)	17 (OVERRIDE2)	
0	0	Selection override with spring return key
0	24VDC	Selection override with push button (switch)
24VDC	0	Not permitted
24VDC	24VDC	Not permitted

Table 11

"SYSTEM STATUS" OUTPUT

A signal that identifies the status of the static outputs is available on pin 4 of the active element. The OUTPUT signal will be fixed to one (24Vdc) or to zero (0Vdc) according to the status of the OSSD's.

"MUTING STATUS" OUTPUT

A signal that identifies the status of the Muting function is available on pin 5. The OUTPUT signal is fixed to one (24Vdc) with active Muting.

"MUTING ENABLE" INPUT

MUTING ENABLE control is used (together with Muting sensors) to trigger the Muting function. For a correct Muting sequence this signal must be 0Vdc prior to energizing any muting sensor. When Muting occurs, MUTING ENABLE signal must be maintained at 0VDC. If increased to +24VDC, Muting function ceases immediately.

To reinstate Muting cycle, MUTING ENABLE signal must be 0VDC.



REER strongly recommend to use actively the MUTING ENABLE input using ML TRX G or MT TRX G models.

When Muting Enable is not needed fix signal to 0Vdc (pin 15).

INTERCONNECTION MODULES MJB1 - MJB2 - MJB3 AND MJB4

The light curtain MI TRX can be integrated by the interconnection modules MJB1 - MJB2 - MJB3 and MJB4. These ones contain clamps, pre-cabled connections and dip switches for selection of the configuration and the two safety relays connected to the light curtain outputs.

- **MJB1 - MJB3 operates with TRX M (muting)** and has: RESTART push button, key selector for the Muting OVERRIDE, muting function active signaling lamp and two safety relays.
- **MJB2 - MJB4 operates with TRX J (without muting)** and has: RESTART push button and two safety relays.

MUTING/OVERRIDE LAMP

Whenever risk assessment so requires, the curtain allows the connection of an external warning lamp of active Muting /Override (pin 1 of the active element), with the following characteristics:

- Active Muting: pin 1 = +24VDC.
- Override function : pin 1: 0 - 24VDC alternate every 400ms
- Maximum supplied power: 2,5W max.



Check the function of this lamp by periodically verifying its lighting/blinking in combination with the verification of light curtain efficiency (see page 34).

MUTING OVERRIDE FUNCTION

The OVERRIDE function must be used when the machine stops due to incorrect Muting activation sequences with the material obstructing the guarded opening.

In this situation, the OSSD outputs are not active as the light curtain and/or at least one Muting sensor is occupied. In this condition the OVERRIDE request led blinks.

This function activates the OSSD outputs making it possible to remove the material that is obstructing the opening concerned.

Throughout the entire phase during which the OVERRIDE function is active, the Muting/Override light is blinking. Check efficiency of this light periodically (during the Muting or Override phases).

Warning!! The Override with pulse command automatically activates the outputs of the light curtain until both the light curtain and the muting sensors are free of obstacles again. During this period, the light curtain is unable to protect access to the guarded opening. Therefore, all operations must be carried out under the strict supervision of expert personnel.

The operator will use the Override mode previously selected (ref. Table 11).

1. Override with continuous action command
2. Override with pulse command

Override with continuous action command

This function is activated driving pins 16 and 17 of the active element to **+24VDC** at the same time (**maximum delay = 400ms**) using a 2-way key selector with spring return;

PIN 16	PIN 17	CONDITION
0	0	Normal operation
24VDC	24VDC	OVERRIDE request

The maximum override duration is 15 minutes; it can be stopped for two different causes.

- **When the selector is released or if the 15 minutes has been elapsed, override ends**, de-activating the OSSD outputs, turning off the muting lamp and showing normal condition on the display. A new override condition can be started, releasing and rearming the selector.
- **Once the opening has been cleared and the sensors are free again**, override ends and GUARD condition (light curtain in normal operation) is activated without necessity of further commands.

Override with pulse command

This function is activated inverting (**maximum delay = 400ms**) the condition of pin 16 and 17 of the active element using a push button (switch). During the override the 16 and 17 are not controlled.

PIN 16	PIN 17	CONDITION
0	24VDC	Normal operation
24VDC	0	OVERRIDE request

The override condition can last a maximum of **15 minutes** (repeatable).

The function can only be re-started by pressing the pushbutton again (**subject to the following conditions**) :

1. Maximum total OVERRIDE time (after *n* consecutive requests) = **60 min**
2. Maximum number of consecutive requests for OVERRIDE = **30**.

The override condition ends when the barrier and sensors are cleared (entrance clear) and the GUARD condition is re-enabled (barrier fully operational) without sending any further commands.

The timer (point 1) and counter (point 2) are reset when one of the following conditions occurs:

- A correct muting sequence.
- A system reset (switched off and then turned on).

DIMENSIONS

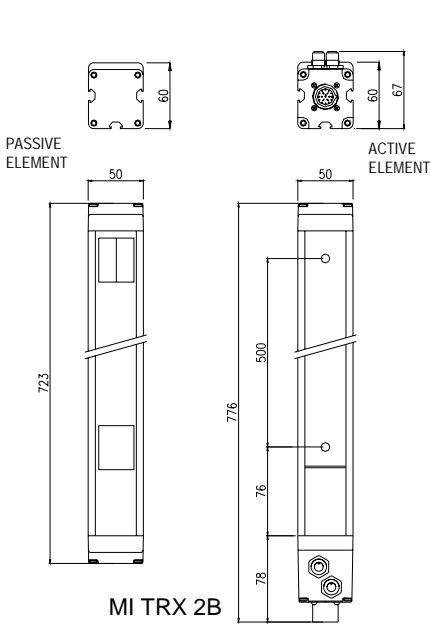

Figure 24

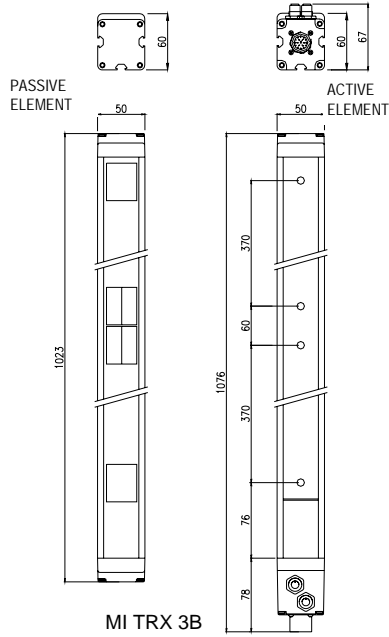

Figure 25

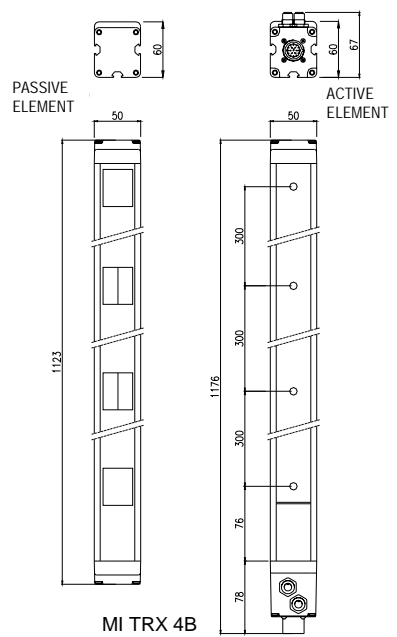
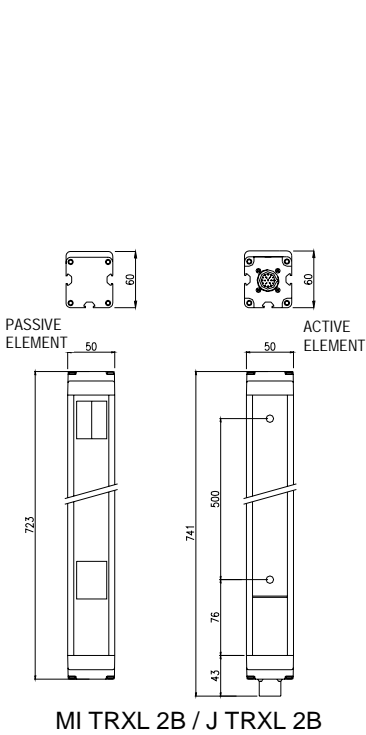
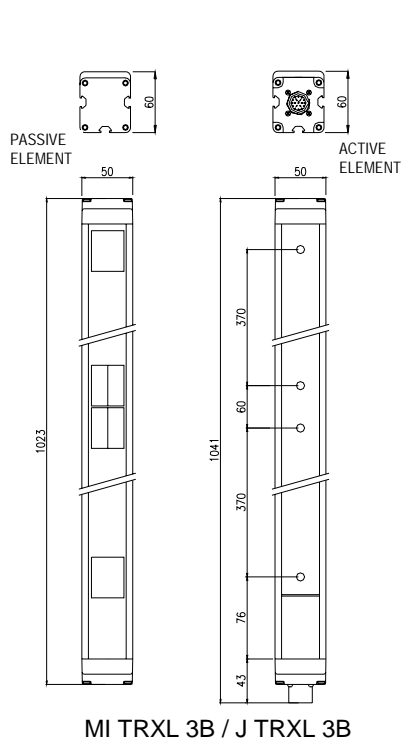

Figure 26



MI TRXL 2B / J TRXL 2B

Figure 27



MI TRXL 3B / J TRXL 3B

Figure 28

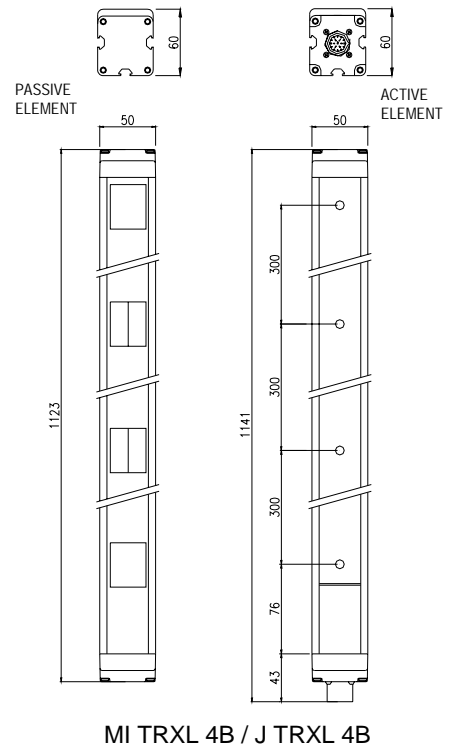

MI TRXL 4B / J TRXL 4B

Figure 29

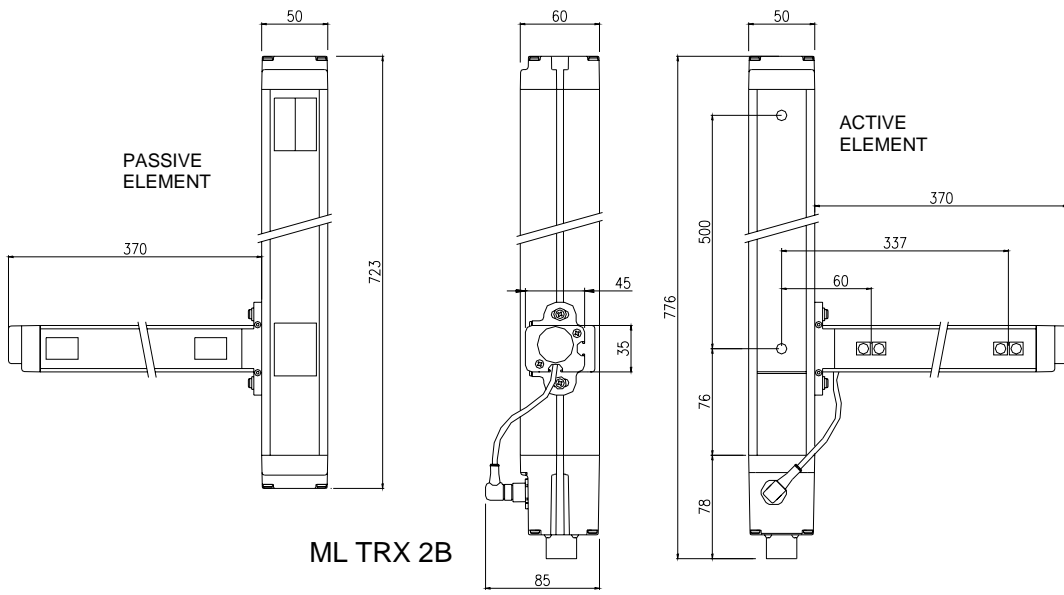

ML TRX 2B

Figure 30

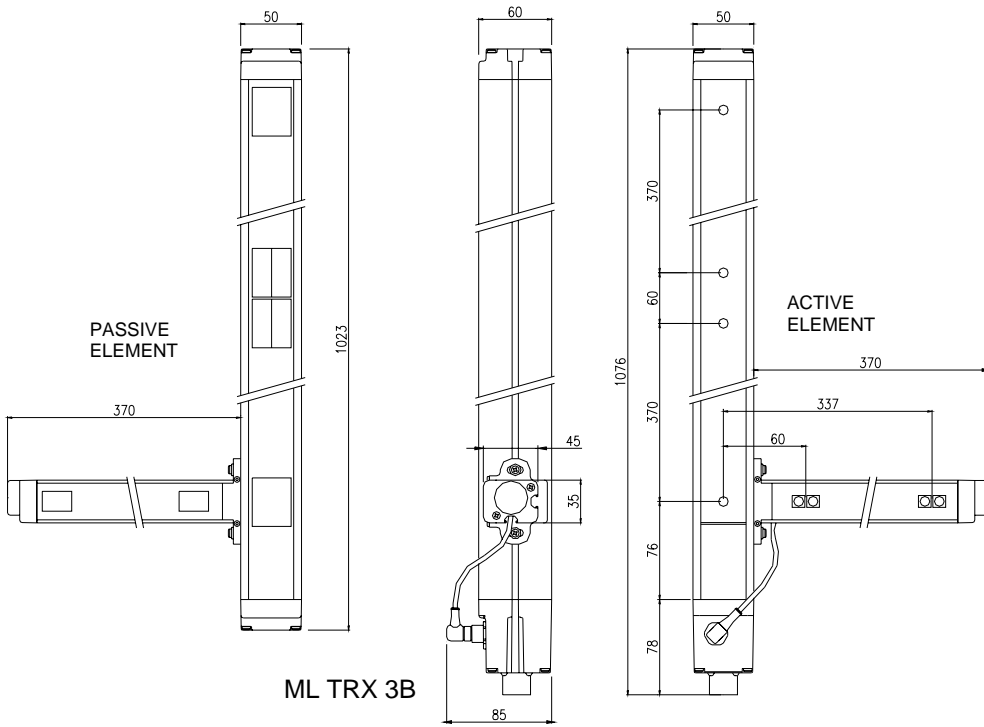

ML TRX 3B

Figure 31

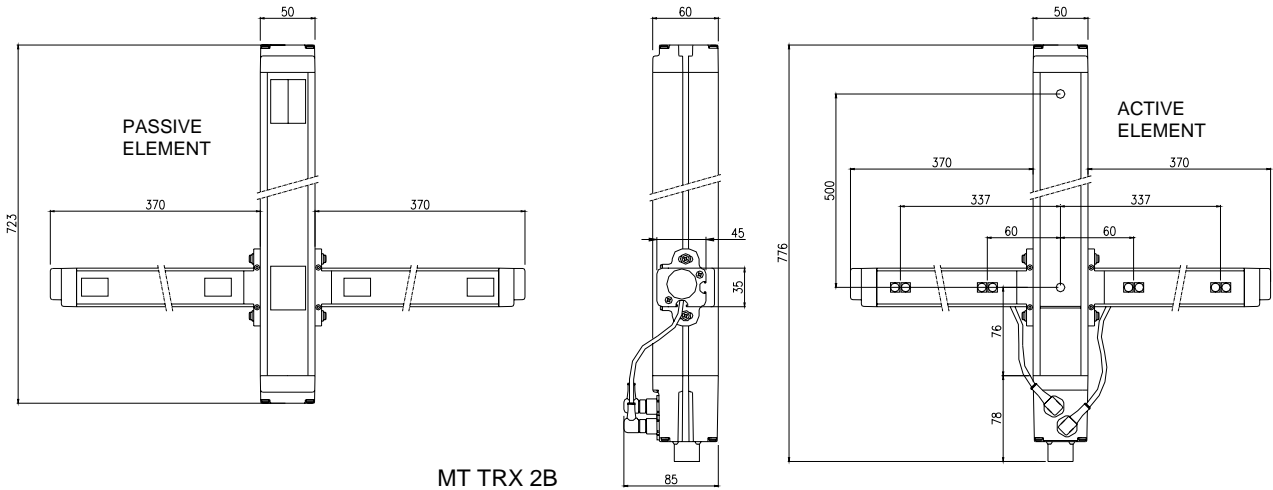

MT TRX 2B

Figure 32

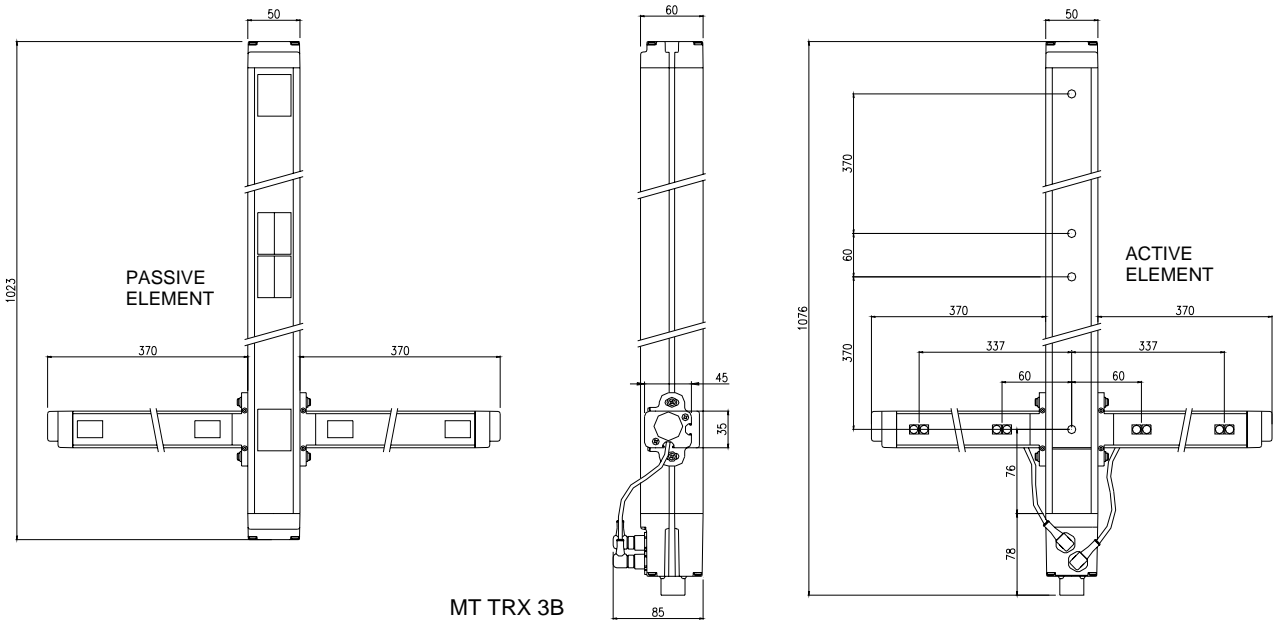

MT TRX 3B

Figure 33

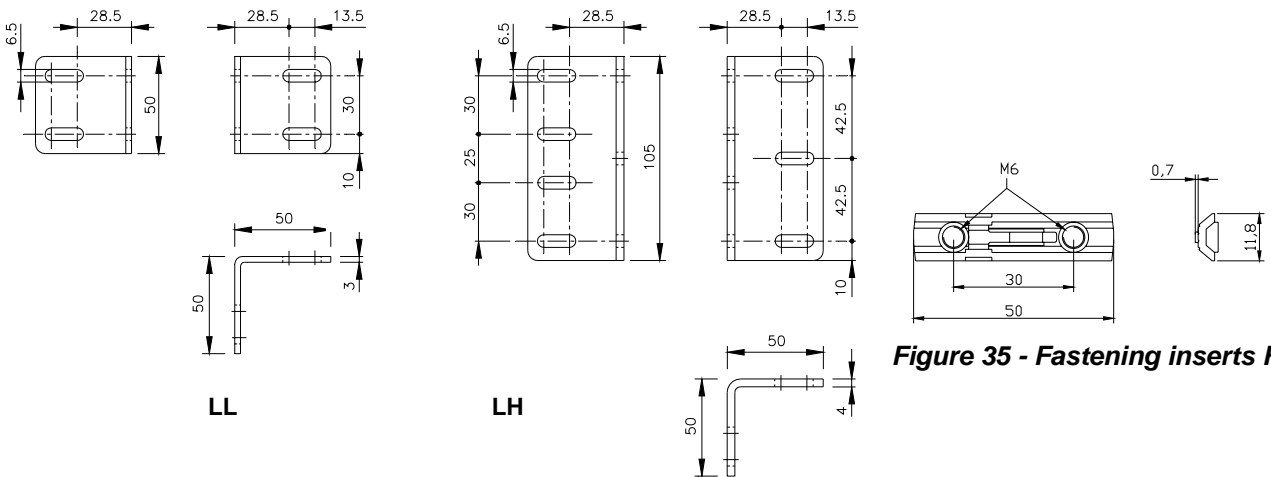

Figure 34 - Fastening brackets LL - LH

Figure 35 - Fastening inserts FI

TECHNICAL CHARACTERISTICS

TECHNICAL CHARACTERISTICS		
Safety Category		4
Power	Vdc	24 ± 20%
Number of beams		2 - 3 - 4
Operating range		0 ÷ 6 (MI TRX / MI TRX L / J TRX L) 0 ÷ 3,5 (ML TRX / ML TRX V) 0 ÷ 3,5 (MT TRX / MT TRX V) 0 ÷ 2 (ML TRX G) 0 ÷ 2 (MT TRX G)
Response time	ms	≤ 10,5
Reset		Automatic or manual (selectable)
Connections		M23 – 19 pins (male) M12 – 5 pins (female) (for the Muting sensors - only in MI TRX models)
Safety outputs		2 PNP self-controlled– 500 mA @ 24 Vcc With short circuit protection, overload, polarity inversion.
Maximum output current	mA	500
Maximum capacity load	µF	2
Maximum off-state tension	V	< 1
Maximum resistance of the connections between the outputs OSSDs and the loads	Ohm	< 25
System Status Output		PNP – 100 mA @ 24 Vdc
Muting Status Output		PNP – 100 mA @ 24 Vdc
Muting lamp Output		PNP – 100 mA @ 24 Vdc
Reaction time on muting signals (sensors)	ms	100
Time-out Muting 2 sensor model		30sec or 90min (selectable)
Time-out Muting 4 sensor model		30sec or excluded (selectable)
Time-out max. Override time	min	15 (renewable)
Max. power	W	4
Protection rating		IP 65
Maximum length of electrical connections	m	100
Operative temperature	°C	0 ÷ 55
Maximum operative humidity	%	95
Dimensions of the light curtain section	mm	50 x 60
Light curtain lifetime		20 years
Safety level	Type 4	IEC 61496-1:2004 IEC 61496-2:2006
	SIL 3	IEC 61508:1998
	SILCL 3	IEC 62061:2005
	PL e - Cat.4	ISO 13849-1 : 2006

ML TRX - ML TRX V - ML TRX G SERIES				
PRE-ASSEMBLED KIT OF MI TRX LIGHT CURTAIN AND SENSOR ELEMENT "ML S"				
Number of beams		2 – 3		
Operating range	m	0 ÷ 3,5		
Operating range (G models)	m	0 ÷ 2		
Muting system		One-way with max. concurrent actuation time 4 sec		
Muting sensors		2 opto-electronic - integrated – pre-aligned – prewired		
Muting sensor detection plane		adjustable height and slope		
MT TRX - MT TRX V - MT TRX G SERIES				
PRE-ASSEMBLED KIT OF MI TRX LIGHT CURTAIN AND SENSOR ELEMENTS "MT SI" AND "MT SE"				
Number of beams		2 – 3		
Operating range	m	0 ÷ 3,5		
Operating range (G models)	m	0 ÷ 2		
Muting system		Two-way with 4 sensors		
Muting sensors		4 opto-electronic - integrated – pre-aligned – prewired		
Muting sensor detection plane		adjustable height and slope		
MT / ML SERIES		2B	3B	
Number of beams		2	3	
Distance between beams	mm	500	400	
Response time	ms	10	10,5	
Overall barrier ht.	mm	776	1076	
PFHd *		4,83E-09	4,92E-09	
DCavg #		98,14%	98,16%	
MTTFd #	years	100		
CCF #		80%		
MI TRX SERIES				
Number of beams of light curtains for detection of body in access control		2 – 3 – 4		
Operating range	m	0 ÷ 6		
Muting system		One-way with 2 sensors and "L" operational logic Two-way with 2 or 4 sensors with max. concurrent actuation time 4 sec Two-way sequential with 4 sensors		
Muting Sensors		External with relay or PNP output		
MI TRX SERIES		2B	3B	4B
Number of beams		2	3	4
Distance between beams	mm	500	400	300
Response time	ms	10	10,5	10,5
Overall barrier ht.	mm	776	1076	1176
PFHd *		4,83E-09	4,92E-09	5,01E-09
DCavg #		98,14%	98,16%	98,19%
MTTFd #	years	100		
CCF #		80%		
J TRX L - MI TRXL SERIES				
Number of beams of light curtains for detection of body in access control		2 – 3 – 4		
Operating range	m	0 ÷ 6		
		2B	3B	4B
Number of beams		2	3	4
Distance between beams	mm	500	400	300
Response time	ms	10	10,5	10,5
Overall barrier ht.	mm	741	1041	1141
PFHd *		4,83E-09	4,92E-09	5,01E-09
DCavg #		98,14%	98,16%	98,19%
MTTFd #	years	100		
CCF #		80%		

* IEC 61508

ISO 13849-1

CHECKOUTS AND MAINTENANCE

Verification of light curtain efficiency.

Before each work shift or before switching on, check the correct operation of the photoelectric light curtain.

Proceed as follows, intercepting the beams using the appropriate test object (available free of charge on request). Refer to Figure 36:

- Intercept each beam with an opaque object, first in the center of the detection zone and then close to the active and passive element.
- Verify that moving the test object close to the two beams, the red led of the active element lights on.

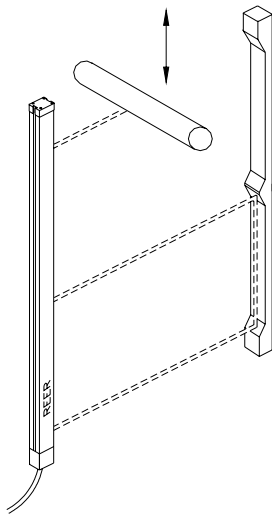

Figure 36

The MI/ML/MT TRX light curtain does not require any specific maintenance operations; however, periodic cleaning of the front protective surfaces of the Emitter and Receiver optics is recommended.

Wipe using a clean, damp cloth; in particularly dusty environments, after cleaning the front surface, the use of an anti-static spray is recommended.

Never use abrasive or corrosive products, solvents or alcohol, which could damage parts. Do not use woollen cloths, that could electrify the front surface.

Grooving or fine scratching of the front plastic surfaces can increase the amplitude of the emission angle of the light curtain, jeopardising detection efficiency in the presence of lateral reflecting surfaces.

This issue can also cause interference by muting sensors and jeopardise reliability of the system, also in absence of lateral reflecting surfaces.

It is therefore fundamental to pay particular attention during the cleaning phases of the curtain front window, especially in environments where abrasive dusts are present. (E.g. cement factories, etc).

If the ORANGE weak signal LED on the Receiver switches on (LED 1 in Figure 23), check that:

- the front surfaces are clean;
- the active and passive elements are aligned correctly.

If the LED stays on, contact the REER service department.

TROUBLESHOOTING

The indications provided on the display of the active element make it possible to trace the cause of a system malfunction. As indicated in the “**INDICATIONS**” chapter of this manual, in the case of a fault, the system is blocked and a numeric code identifying the type of fault is shown on the display of the receiver. (See the table below). As soon as the error condition is removed, the code is cleared from the display and the system restarts automatically.

CODE (Flashing)		DIAGNOSIS	RESOLUTION
F		It appears alternatively to the fault code	
CONFIGURATION ERRORS	C	Incorrect system configuration (the flashing led together with C, indicates the type of incorrect configuration) see page 21.	Check the connections related to the choice of the configuration.
	L	Incorrect connection or faulty Muting lamp	Check the efficiency of the MUTING lamp.
	U	Incorrect signal connection "SYSTEM STATUS" or overload	Check connections of the clamp 4.
	J	Incorrect signal connection "MUTING STATUS" or overload	Check connections of the clamp 5.
	2	Outputs OSSD incorrectly connected to +24VDC	Carefully check the connections of the clamps 2 and 3 (OSSD) on the connector. Warning : the load should be positioned between the outputs (OSSD) and 0 Vdc.
	6	Short circuit between the outputs OSSD	Carefully check the connection of clamps 2 and 3.
	E	Absence of signal for enablement/de-enablement of external contactors or feedback of absent connectors	Check the connections of the clamps 11 and 18.
	H	Incorrect initial OVERRIDE configuration	Check the connections of the clamps 16 and 17.
	II	<ul style="list-style-type: none"> Unstable Muting signals Light curtain configured for 2 sensors but 3 or 4 sensors registered (the corresponding led does flashes) 	<ul style="list-style-type: none"> Check the position of the muting sensors Check the number of sensors connected and the configuration selection
FAULTS	0	Overload on the outputs OSSD	Carefully check the connection of clamps 2 and 3 (OSSD) on the connector. If necessary re-dimension the load by reducing the request to a max. of 500 mA (2.2 µF)
	3	Internal error	Send the equipment for repairs to an REER laboratory.
	4	Internal error	Send the equipment for repairs to an REER laboratory.
	5	Internal error on the OSSD outputs (or incorrect connections)	Carefully check the connections of clamps 2 and 3 (OSSD) on the connector. These clamps may be directly connected to + 24 Vdc or to 0 Vdc. Otherwise send the equipment for repairs to an REER laboratory.
	A	Internal error	Send the equipment for repairs to an REER laboratory.

CODE (Not flashing)		DIAGNOSIS	RESOLUTION
FAULTS	0	Overload on the outputs OSSD	Carefully check the connection of clamps 2 and 3 (OSSD) on the connector. If necessary re-dimension the load by reducing the request to a max. of 500 mA (2.2 µF)
	1	Interfering Emitter identified (THE CODE REMAINS FOR AT LEAST 30s)	Carefully search for the faulty Emitter and intervene in one of the following ways: <ul style="list-style-type: none"> • Swap the position of the Emitter and the active element • Move the interfering Emitter in order to avoid the active element from illuminating • Conceal the beams from the interfering Emitter using opaque protections
	t (flashing)	Override with pulse command expired	Reset the system

ACCESSORIES

MODEL	DESCRIPTION	CODE
JANUS MJB1	Muting Junction Box	1360930
JANUS MJB2	Junction Box	1360931
JANUS MJB3	Muting Junction Box	1360932
JANUS MJB4	Junction Box	1360934

MI/ML/MT TRX ACTIVE ELEMENTS CONNECTORS		
CJ3	M23 female connectors 19 poles 3 m cable	1360950
CJ5	M23 female connectors 19 poles 5 m cable	1360951
CJ10	M23 female connectors 19 poles 10 m cable	1360952
CJ15	M23 female connectors 19 poles 15 m cable	1360953
CJ20	M23 female connectors 19 poles 20 m cable	1360954
CJM23	M23 female connectors 19 poles (not wired)	1360955

CABLES WITH 2 CONNECTORS FOR MI/ML/MT TRX ACTIVE ELEMENT AND MUTING BOX		
CJBR3	3 m cable with 2 M12 female connectors	1360970
CJBR5	5 m cable with 2 M12 female connectors	1360971
CJBR10	10 m cable with 2 M12 female connectors	1360972

FIXING ACCESSORIES		
LL	Set of 4 fastening brackets LL type	7200037
LH	Set of 4 fastening brackets LH type	7200081
FI 4	Set of 4 fastening inserts	1330972
FI 6	Set of 6 fastening inserts	1330973

GUARANTEE

All new MI/ML/MT TRX systems are guaranteed by REER for a period of 12 (twelve) months under normal working conditions, against defects due to faulty materials and workmanship.

During the aforesaid period, REER promises to replace faulty parts free of charge. This guarantee covers both material and labour.

REER reserves the right to decide whether to repair equipment or replace it with equipment of the same type or having the same characteristics.

The validity of this guarantee is subject to the following conditions:

- The user must notify REER of the fault within twelve months following the date of delivery of the product.
- The equipment and all parts thereof must be in the condition in which they were supplied by REER.
- The defect or malfunction must not arise directly or indirectly from:
 - Improper use
 - Non-observance of the instructions for use;
 - Negligence, inexperience, improper maintenance;
 - Repairs, modifications and adjustments carried out by personnel not authorised by REER, tampering, etc.;
 - Accidents or collisions (also during transportation or due to acts of God);
 - Other reasons for which REER cannot be held responsible.

Repairs will be carried out at REER's laboratories, to which the material must be consigned or forwarded: transport costs and any damage or loss of material during transportation will be charged to the Customer.

All replaced products and parts are property of REER.

REER does not recognise any other form of guarantee or rights other than those expressly stated above; no requests for compensation for damages incurred for costs, suspension of activities or any other events or circumstances related in any way to malfunctioning of the product or any parts thereof will be taken into consideration.

In order to ensure the correct operation of the photoelectric light curtain, careful and full compliance with all the rules, instructions and warnings stated in this manual is essential. REER s.p.a. declines all responsibility for events arising from non-compliance with all or part of the aforesaid instructions.

Specifications subject to change without warning. • No part of this manual may be reproduced without the prior consent of REER.