



Safety. Detection. Control.



Michtron

Measurement and Automation

Light curtains range



Aluminum casing
Anodized

-10 ... +55° C
Operating temperature
Ideal also in cold storage facilities

Software configuration
Easy to use with extensive
configurable parameters choice

Caps
Glass reinforced polypropylene

M12 connectors
Cables easy to source
and replace

IP65 and IP67

Analogue and
Digital readings
2 outputs

Compact size
Only 30 x 28 mm

Status indicating display
Including alignment aids

Michon

measurement and
automation light curtains...

...for industrial and civil applications



www.reersafety.com

Micron



A unique range

Light curtains for industrial and civil applications where it is necessary to detect, measure, and recognise objects.

Depending on the number and position of the beams engaged by an object, Micron can provide real time information to a PLC or PC in order to: **detect the presence or absence of objects, perform a count, detect a position, detect a shape or a profile, measure dimensions.**

Models MI AV equipped with two analog outputs (0/10 VDC) with programmable functions and two programmable digital outputs.

Models MI AC equipped with two analog outputs (4/20 mA) with programmable functions and two programmable digital outputs.

Models MI B equipped with an RS 485 serial interface with programmable functions and two programmable digital outputs.

Models MI C equipped with two antivalent solid state outputs.

MicronConfigurator software for PC, with graphic user interface, is supplied with each light curtain (models A and B only). Models A and B are provided with an M5 4-pole connector for parameter configuration and monitoring of the light curtain.

measurement and automation light

www.reersafety.com

An extensive and comprehensive range of measurement and detection light curtains

Unique features allow do deliver optimal results in most applications

Typical applications



Measurement of the height of objects in transit on conveyor systems

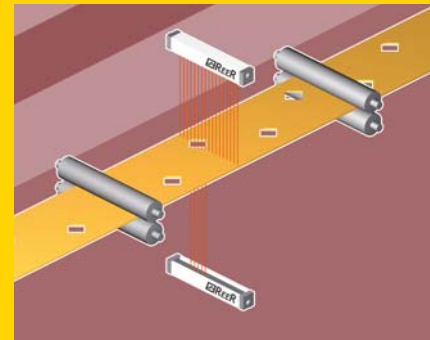

Quality control: verification of presence, absence or position of holes



Two-dimensional detection of objects in transit on conveyor systems with use of 2 light curtains

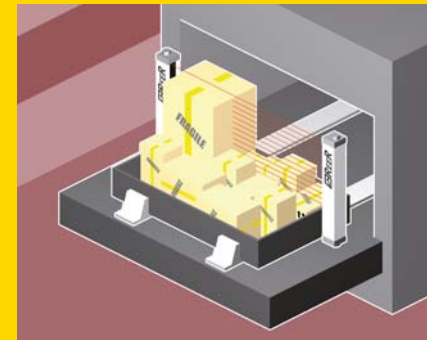

Automatic warehouses: detection of maximum height of the objects present in the boxes for efficient management of the machine's capacity

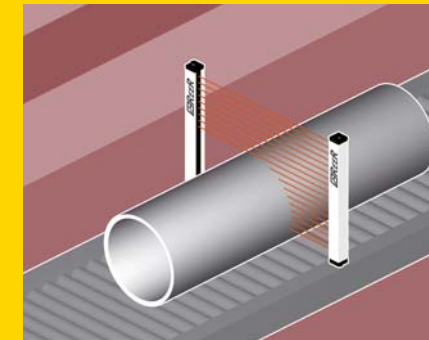

Measurement and identification of cylinders of various sizes



Detection of position and profile of pieces in automatic painting systems

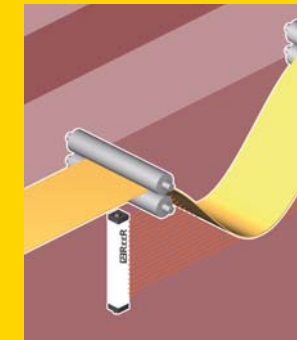

Loop control

Micron A

Ideal for object measurement and detection of dimensional limits.

AV (0/10 VDC) analogue output, AC (4/20 mA) analogue output.

Solution providing simple measurement with easy interfacing.

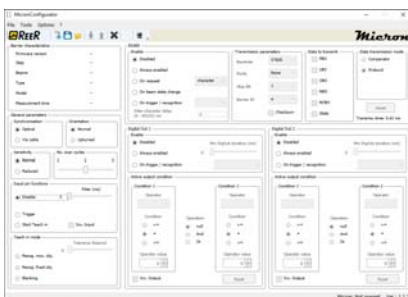

MicronConfigurator

An extensive and easy-to-use configuration software is included with Micron A and B.

Micron B

Ideal for dimensional measurement, detection of object profile and position.

RS 485 serial line and two solid state outputs 0/24V with programmable functions.

Solution providing complete and detailed information on the status of each beam via the RS 485 serial line and, by means of the two solid state outputs, further on/off information related to the occurrence of the programmed conditions.

Micron C

Ideal for piece counting and detection of object presence/absence in the controlled field.

Two solid state antivalent outputs 0/24V without the need of programming.

Solution providing simple on/off information related to the status of the controlled area.

Technical features

- Controlled heights: 150 ... 3000 mm
- Beam spacing: 10, 25, 30, 50, 75 mm
- Max. range:
 - 10 m: 10, 30 mm beam spacing models
 - 18 m: 25, 50, 75 mm beam spacing models
- Scan cycles: 1, 2, 3 (selectable)
- Synchronisation between emitter and receiver: optical or via cable (selectable)
- Status display for operating status monitoring and light curtain self-diagnosis
- Power supply: 24 VDC +/-20%
- Max. length connection cables between light curtain and interface: 100 m
- Operating temperature: -10 ... +55° C
- Protection rating: IP65 and IP67
- Fastening mode: back slot, or to the top and lower end with optional rotating brackets
- Cross-section dimensions: 28 x 30 mm

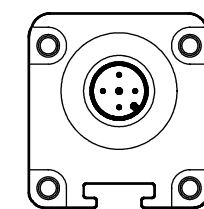

Emitter
M12 5-pole

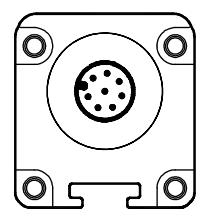

Receiver
M12 8-pole

Light curtains

Micron

Light curtains

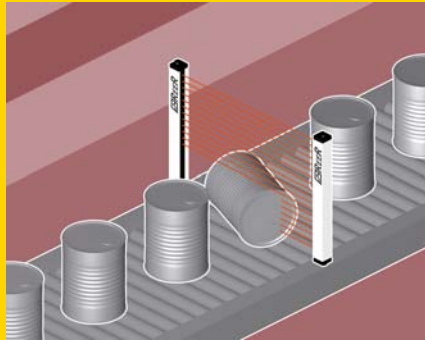

Quality control: verification of correct positioning of objects

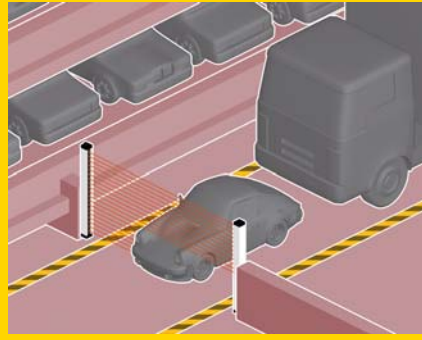

Detection of overall dimensional limits of vehicles for vehicle handling in automatic parking garages

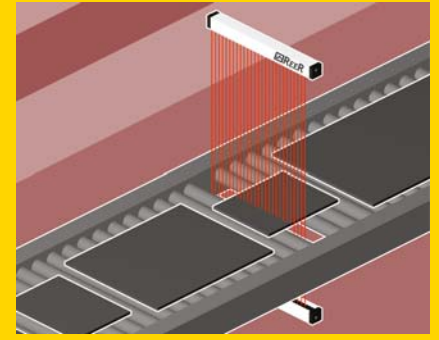

Measurement of the width and position of panels or sheets of material in transit on roller units or conveyor belts

Special application

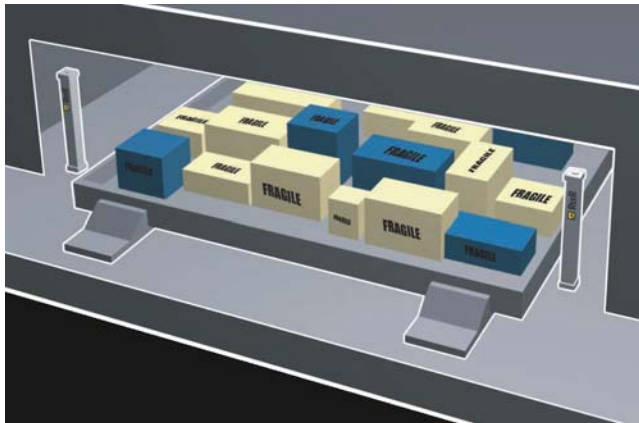

Vertical warehouse storage systems

Special model with beam spacing: 25, 50, 75 mm.

The special optics of these light curtains allow detection of small objects in quick motion.

This particular application requires to detect the maximum height of the stored goods in order to maximise the system overall capacity.

Small high-speed moving items are detected thanks to a custom developed optic set.

Furthermore, Micron is customised to satisfy the needs of automated warehousing applications, including: **accuracy of the reading in every position of the storing drawer** (left, right or centre positioned), **ability of measuring small dimension objects** (less than 2 mm at 600 mm/sec) particularly during the high-speed transit of the storing drawers in front of the barrier, and **immunity to optical reflections**.



Safety. Detection. Control.



More than 50 years of quality and innovation

Founded in Turin, Italy in 1959, ReeR distinguished itself for its strong commitment to innovation and technology.

A steady growth throughout the years allowed ReeR to become a point of reference in the safety automation industry at a worldwide level.

The Safety Division is in fact today a world leader in the development and manufacturing of safety optoelectronic sensors and controllers.

ReeR is ISO 9001, ISO 14001 and BS OHSAS 18001 certified.

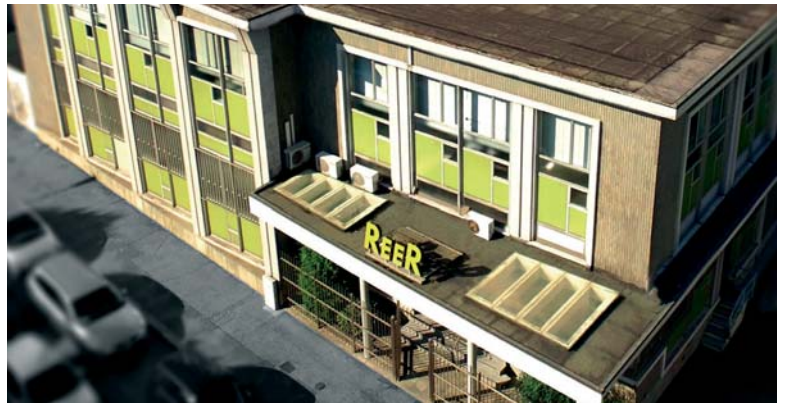

Distributed in the USA by



Norstat Inc.
300 Roundhill Drive
Rockaway, NJ 07866

Phone: 973-586-2500
Fax: 973-586-1590
www.norstat.com



Rev. 1.2
March 2017
8946240
Printed in Italy

Brochure Micron English

ReeR SpA does not guarantee that product information in this catalogue are the most current available. ReeR SpA reserves the right to make changes to the products described without notice and assumes no liability as a result of their use or application. Our goal is to keep the information on this catalogue timely and accurate, however ReeR SpA accepts no responsibility or liability whatsoever with regard to the information on this catalogue. Reproduction is not authorised, except with the expressed permission of ReeR SpA.