



**NORSTAT** INC.

# Safety Relay Product Catalog



# Achieving more together

The electronics industry offers a multitude of wide-ranging possibilities like no other. Companies looking to take advantage need a strong partner. With experience gained over many years and comprehensive service, the CM Group offers customised consultation and solutions.

The three companies **CM Manufactory GmbH**, **CM-Delker Systems GmbH** and **CM Security GmbH** place their focus on "Achieving more together". The three divisions are split into the following areas:

- Development and production of electronic assemblies and systems
- Development and production of safety relays
- Manufacture of customer-specific cable harnesses
- Safety technology, alarm technology, video technology, access control systems

By bringing all these areas together, the CM Group can offer customer-specific system solutions.



## Our Product Range



## Ideal compliance with all safety requirements



We develop electronic safety relays for all standard applications as well as for special customer-specific requirements. **You are welcome to brand under your own label.** We also offer custom housing shapes in various colours, with removable or fixed screw or spring terminals.

## Fields of competence in safety relays

- In-house development and production
- Smallest housing with a low design height
- Relay for special applications
- Testing programmes developed in-house
- Special developments tailored to your requirements

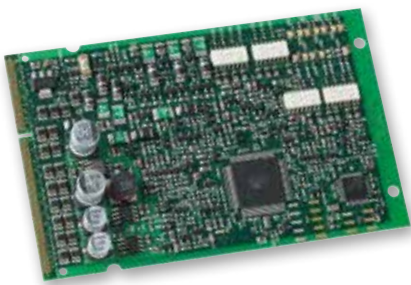

**Certified**

to DIN EN ISO 9001 No. S 89403

Approvals: TÜV/UL/C-UL

**TÜV  
type-  
tested**

**cUL<sup>us</sup>  
LISTED**



# Product overview of safety relays

| Contacts |     |                    |       | Operating voltage |       |    |    |    | EN 13849-1: Category |                  |                    |           |     | EN 13849-1: PL |   |   |   |   | Page |   |   |   |
|----------|-----|--------------------|-------|-------------------|-------|----|----|----|----------------------|------------------|--------------------|-----------|-----|----------------|---|---|---|---|------|---|---|---|
| N/O      | N/C | Auxiliary contacts | Other | DC                | AC/DC | AC | AC | AC | Housing width in mm  | Start monitoring | Switching capacity | Approvals | ErP | B/1            | 2 | 3 | 4 | a |      | b | c | d |

## 1 | Safety relays for emergency stop circuits and safety door monitoring contacts

|                     |   |   |   |   |   |   |   |   |      |          |                    |               |   |   |   |                |   |   |   |   |                |   |    |
|---------------------|---|---|---|---|---|---|---|---|------|----------|--------------------|---------------|---|---|---|----------------|---|---|---|---|----------------|---|----|
| <b>SAFE 4</b>       | 3 | 1 |   |   | x | x | x |   | 22.5 | x        | 5 A                | TÜV, UL, C-UL |   | √ | √ | √              | √ | √ | √ | √ | √              | √ | 8  |
| <b>SAFE 4.1</b>     | 3 | 1 |   |   | x | x | x |   | 22.5 |          | 5 A                | TÜV, UL, C-UL | √ | √ | √ | √              | √ | √ | √ | √ | √              | √ | 8  |
| <b>SAFE 4.1 eco</b> | 3 | 1 |   |   | x | x | x |   | 22.5 | Optional | 5 A                | TÜV, UL, C-UL | √ | √ | √ | √              | √ | √ | √ | √ | √              | √ | 9  |
| <b>SAFE 4.2 eco</b> | 3 | 1 |   |   | x | x | x |   | 22.5 | Optional | 5 A                | TÜV, UL, C-UL | √ | √ | √ | √              | √ | √ | √ | √ | √              | √ | 9  |
| <b>SAFE 4.3 eco</b> | 3 | 1 |   |   | x | x | x |   | 22.5 | Optional | 5 A                | TÜV, UL, C-UL | √ | √ | √ | √              | √ | √ | √ | √ | √              | √ | 9  |
| <b>SAFE 5</b>       | 2 |   |   |   | x |   |   |   | 22.5 | x        | 6 A                | TÜV, UL, C-UL |   | √ | √ | √ <sup>3</sup> |   | √ | √ | √ | √ <sup>3</sup> | √ | 10 |
| <b>SAFE 5.1</b>     | 2 |   |   |   | x |   |   |   | 22.5 |          | 6 A                | TÜV, UL, C-UL |   | √ | √ | √ <sup>3</sup> |   | √ | √ | √ | √ <sup>3</sup> | √ | 10 |
| <b>SAFE C1</b>      | 3 |   | 4 | x |   |   |   |   | 22.5 | Optional | 1.8 A <sup>2</sup> | TÜV, UL, C-UL |   | √ | √ | √              | √ | √ | √ | √ | √              | √ | 10 |
| <b>SAFE FLEX</b>    | 2 |   |   | x |   |   |   |   | 22.5 | Optional | 6 A                | TÜV, UL, C-UL |   | √ | √ | √              | √ | √ | √ | √ | √              | √ | 11 |
| <b>SAFE 1</b>       | 3 | 1 |   |   | x |   |   |   | 22.5 |          | 5 A                | TÜV, UL, C-UL |   | √ | √ | √ <sup>3</sup> |   | √ | √ | √ | √ <sup>3</sup> |   | 11 |
| <b>SAFE 1.1</b>     | 3 | 1 |   |   | x |   |   |   | 22.5 | x        | 5 A                | TÜV, UL, C-UL |   | √ | √ | √ <sup>3</sup> |   | √ | √ | √ | √ <sup>3</sup> |   | 11 |
| <b>SAFE 2</b>       | 2 |   |   |   | x |   |   |   | 22.5 | x        | 6 A                | TÜV, UL, C-UL |   | √ | √ | √              | √ | √ | √ | √ | √              | √ | 12 |
| <b>SAFE 2.1</b>     | 2 |   |   |   | x |   |   |   | 22.5 |          | 6 A                | TÜV, UL, C-UL |   | √ | √ | √              | √ | √ | √ | √ | √              | √ | 12 |
| <b>SAFE S.6</b>     | 2 |   |   |   | x | x | x | x | 45   |          | 6 A                | TÜV, UL, C-UL |   | √ | √ | √              | √ | √ | √ | √ | √              | √ | 12 |
| <b>SAFE G1</b>      |   |   | 4 | x |   |   |   |   | 18   | Optional | 0.4 A              | TÜV, UL, C-UL |   | √ | √ | √              | √ | √ | √ | √ | √              | √ | 13 |
| <b>SAFE G2</b>      |   |   | 4 | x |   |   |   |   | 18   | Optional | 0.4 A              | TÜV, UL, C-UL |   | √ | √ | √              | √ | √ | √ | √ | √              | √ | 13 |
| <b>SAFE GT</b>      |   |   | 4 | x |   |   |   |   | 18   | Optional | 0.4 A              | TÜV, UL, C-UL |   | √ | √ | √              | √ | √ | √ | √ | √              | √ | 14 |
| <b>SAFE GL</b>      |   |   | 4 | x |   |   |   |   | 18   | Optional | 0.4 A              | TÜV, UL, C-UL |   | √ | √ | √              | √ | √ | √ | √ | √              | √ | 14 |

## 2 | Safety relays for emergency stop circuits and safety door applications with switching delay

|                    |     |   |   |   |   |  |  |  |    |          |       |                |  |   |   |   |   |   |   |   |   |   |    |
|--------------------|-----|---|---|---|---|--|--|--|----|----------|-------|----------------|--|---|---|---|---|---|---|---|---|---|----|
| <b>SAFE T...</b>   | 2+2 | 1 |   |   | x |  |  |  | 35 | Optional | 6 A   | TÜV, UL, C-UL  |  | √ | √ | √ | √ | √ | √ | √ | √ | √ | 15 |
| <b>SAFE T ON</b>   | 2+2 | 1 |   |   | x |  |  |  | 35 | Optional | 6 A   | TÜV, UL, C-UL  |  | √ | √ | √ | √ | √ | √ | √ | √ | √ | 15 |
| <b>SAFE GT</b>     |     |   | 4 | x |   |  |  |  | 18 | Optional | 0.4 A | TÜV, UL, C-UL  |  | √ | √ | √ | √ | √ | √ | √ | √ | √ | 16 |
| <b>SAFE FLEX T</b> | 4+2 | 1 | 1 | x |   |  |  |  | 45 | Optional | 6 A   | TÜV, UL, C-UL* |  | √ | √ | √ | √ | √ | √ | √ | √ | √ | 16 |

## 3 | Safety relays for safety switch mats and safety strips

|                 |   |   |   |   |   |  |   |  |      |          |                    |               |  |   |   |   |   |   |   |   |   |   |    |
|-----------------|---|---|---|---|---|--|---|--|------|----------|--------------------|---------------|--|---|---|---|---|---|---|---|---|---|----|
| <b>SAFE CM</b>  |   |   | 4 | x |   |  |   |  | 22.5 | Optional | 1.8 A <sup>2</sup> | TÜV, UL, C-UL |  | √ | √ | √ | √ | √ | √ | √ | √ | √ | 17 |
| <b>SAFE M</b>   | 3 | 1 |   |   | x |  | x |  | 22.5 | x        | 5 A                | TÜV, UL, C-UL |  | √ | √ | √ |   | √ | √ | √ | √ | √ | 17 |
| <b>SAFE M.1</b> | 3 | 1 |   |   | x |  | x |  | 22.5 |          | 5 A                | TÜV, UL, C-UL |  | √ | √ | √ |   | √ | √ | √ | √ | √ | 17 |
| <b>SAFE 2.2</b> | 2 |   |   |   | x |  |   |  | 22.5 |          | 6 A                | TÜV, UL, C-UL |  | √ | √ | √ | √ | √ | √ | √ | √ | √ | 18 |
| <b>SAFE G1</b>  |   |   | 4 | x |   |  |   |  | 18   | Optional | 0.4 A              | TÜV, UL, C-UL |  | √ | √ | √ | √ | √ | √ | √ | √ | √ | 18 |
| <b>SAFE G2</b>  |   |   | 4 | x |   |  |   |  | 18   | Optional | 0.4 A              | TÜV, UL, C-UL |  | √ | √ | √ | √ | √ | √ | √ | √ | √ | 18 |
| <b>SAFE GT</b>  |   |   | 4 | x |   |  |   |  | 18   | Optional | 0.4 A              | TÜV, UL, C-UL |  | √ | √ | √ | √ | √ | √ | √ | √ | √ | 19 |
| <b>SAFE GL</b>  |   |   | 4 | x |   |  |   |  | 18   | Optional | 0.4 A              | TÜV, UL, C-UL |  | √ | √ | √ | √ | √ | √ | √ | √ | √ | 19 |

| Contacts |     |                    |                       | Operating voltage |            |         |          |          | EN 13849-1: Category |                  |                    |           | EN 13849-1: PL |     |   |   |   | Page |   |   |   |   |
|----------|-----|--------------------|-----------------------|-------------------|------------|---------|----------|----------|----------------------|------------------|--------------------|-----------|----------------|-----|---|---|---|------|---|---|---|---|
| N/O      | N/C | Auxiliary contacts | Semiconductor outputs | DC 24 V           | AC/DC 24 V | AC 48 V | AC 110 V | AC 230 V | Housing width in mm  | Start monitoring | Switching capacity | Approvals | ErP            | B/1 | 2 | 3 | 4 | a    | b | c | d | e |

#### 4 | Safety relays for non-contact safety devices

|                    |   |                 |   |   |   |  |  |  |      |          |                     |               |   |                 |   |   |   |   |   |   |   |    |
|--------------------|---|-----------------|---|---|---|--|--|--|------|----------|---------------------|---------------|---|-----------------|---|---|---|---|---|---|---|----|
| <b>SAFE L.2</b>    | 3 |                 |   |   | x |  |  |  | 22.5 | Optional | 6 A                 | TÜV, UL, C-UL |   | √ <sup>*4</sup> |   |   | √ | √ | √ | √ | √ | 21 |
| <b>SAFE CL</b>     |   |                 | 4 | x |   |  |  |  | 22.5 | Optional | 1.8 A <sup>*2</sup> | TÜV, UL, C-UL |   | √               | √ | √ | √ | √ | √ | √ | √ | 21 |
| <b>SAFE FLEX</b>   | 2 |                 |   |   | x |  |  |  | 22.5 | Optional | 6 A                 | TÜV, UL, C-UL | √ | √               | √ | √ | √ | √ | √ | √ | √ | 22 |
| <b>SAFE FLEX L</b> |   | TÜV, UL*, C-UL* |   |   |   |  |  |  |      |          |                     |               |   |                 |   |   |   |   |   |   |   |    |
| <b>SAFE G1</b>     |   |                 | 4 | x |   |  |  |  | 18   | Optional | 0.4 A               | TÜV, UL, C-UL |   | √               | √ | √ | √ | √ | √ | √ | √ | 23 |
| <b>SAFE G2</b>     |   |                 | 4 | x |   |  |  |  | 18   | Optional | 0.4 A               | TÜV, UL, C-UL |   | √               | √ | √ | √ | √ | √ | √ | √ | 24 |
| <b>SAFE GT</b>     |   |                 | 4 | x |   |  |  |  | 18   | Optional | 0.4 A               | TÜV, UL, C-UL |   | √               | √ | √ | √ | √ | √ | √ | √ | 24 |
| <b>SAFE GL</b>     |   |                 | 4 | x |   |  |  |  | 18   | Optional | 0.4 A               | TÜV, UL, C-UL |   | √               | √ | √ | √ | √ | √ | √ | √ | 24 |

NEW

#### 5 | Safety relays for two-hand circuits

|                  |   |   |   |   |   |   |   |   |      |          |                     |               |  |   |   |   |   |   |   |   |   |    |
|------------------|---|---|---|---|---|---|---|---|------|----------|---------------------|---------------|--|---|---|---|---|---|---|---|---|----|
| <b>SAFE Z.2</b>  | 2 | 1 | 1 |   | x | x | x | x | 22.5 |          | 6 A                 | TÜV, UL, C-UL |  | √ | √ | √ | √ | √ | √ | √ | √ | 25 |
| <b>SAFE CZ</b>   |   |   |   | 4 | x |   |   |   | 22.5 |          | 1.8 A <sup>*2</sup> | TÜV, UL, C-UL |  | √ | √ | √ | √ | √ | √ | √ | √ | 25 |
| <b>SAFE FLEX</b> | 2 |   |   |   | x |   |   |   | 22.5 | Optional | 6 A                 | TÜV, UL, C-UL |  | √ | √ | √ | √ | √ | √ | √ | √ | 26 |

#### 6 | Safety relays for contact multiplication in emergency off circuits, safety door monitoring circuits and other safety circuits

|                    |   |   |    |  |   |   |   |   |      |  |     |               |   |   |   |   |   |   |   |   |   |    |
|--------------------|---|---|----|--|---|---|---|---|------|--|-----|---------------|---|---|---|---|---|---|---|---|---|----|
| <b>SAFE X4</b>     | 4 | 1 |    |  | x | x | x | x | 22.5 |  | 6 A | TÜV, UL, C-UL | √ | √ | √ | √ | √ | √ | √ | √ | √ | 27 |
| <b>SAFE X4.1</b>   |   |   |    |  |   |   |   |   |      |  |     |               |   |   |   |   |   |   |   |   |   |    |
| <b>SAFE IR.2.2</b> |   |   | 2W |  | x |   |   |   | 22.5 |  | 5 A |               |   | Ⓐ |   |   |   |   |   |   |   | 27 |

#### 7 | Safety relays for emergency off, safety door, light barrier and two-hand applications

|                    |     |   |   |  |   |  |  |  |      |          |     |                 |  |   |   |   |   |   |   |   |   |    |
|--------------------|-----|---|---|--|---|--|--|--|------|----------|-----|-----------------|--|---|---|---|---|---|---|---|---|----|
| <b>SAFE FLEX</b>   | 2   |   |   |  | x |  |  |  | 22.5 | Optional | 6 A | TÜV, UL, C-UL   |  | √ | √ | √ | √ | √ | √ | √ | √ | 28 |
| <b>SAFE FLEX T</b> | 4+2 | 1 | 1 |  | x |  |  |  | 45   | Optional | 6 A | TÜV, UL*, C-UL* |  | √ | √ | √ | √ | √ | √ | √ | √ | 28 |

#### 8 | Safe standstill monitor

|                |   |  |  |  |   |  |  |  |      |  |     |                 |  |   |   |   |   |   |   |   |   |    |
|----------------|---|--|--|--|---|--|--|--|------|--|-----|-----------------|--|---|---|---|---|---|---|---|---|----|
| <b>SAFE SM</b> | 2 |  |  |  | x |  |  |  | 22.5 |  | 6 A | TÜV, UL*, C-UL* |  | √ | √ | √ | √ | √ | √ | √ | √ | 29 |
|----------------|---|--|--|--|---|--|--|--|------|--|-----|-----------------|--|---|---|---|---|---|---|---|---|----|

#### 9 | Multi-functional relay with optional properties for lift applications, certified to EN 81

|                |  |  |   |   |  |  |  |  |    |          |       |               |  |   |   |   |   |   |   |   |   |    |
|----------------|--|--|---|---|--|--|--|--|----|----------|-------|---------------|--|---|---|---|---|---|---|---|---|----|
| <b>SAFE GL</b> |  |  | 4 | x |  |  |  |  | 18 | Optional | 0.4 A | TÜV, UL, C-UL |  | √ | √ | √ | √ | √ | √ | √ | √ | 30 |
|----------------|--|--|---|---|--|--|--|--|----|----------|-------|---------------|--|---|---|---|---|---|---|---|---|----|

NEW

\* Certification requested

\*<sup>2</sup> SUM current

\*<sup>3</sup> Supply voltage can be switched off on both sides; protected cable routing (fault protection due to parasitic voltage) and regular actuation, e.g. during maintenance, up to Cat. 3

\*<sup>4</sup> Can only be used with light barriers that have an integrated self-testing function

Depending on wiring, suitable for up to max. Cat. 4

Ⓐ

√ suitable x available

N/O normally open

N/C normally closed

W Converter

TÜV  
type-  
tested

UL  
LISTED



All of our devices are produced in compliance with RoHS. They must be assembled and commissioned according to the operating instructions. The approvals for our products are indicated in the table.

# 1 | Emergency off circuits and safety door monitoring contacts



## SAFE 4 / SAFE 4.1

|                         |   |
|-------------------------|---|
| Application             | For one and two-channel applications, including with AC supply  |
| Approval                | TÜV, UL, C-UL   |
| Contacts                | 3 normally open, 1 normally closed  |
| Special characteristics | Visual switching status indication and mains control via LED<br>Cross-circuit protection - with (SAFE 4) and without (SAFE 4.1)<br>Monitoring of the START button |
| LED                     | Mains, channel 1 and channel 2  |
| Ambient temperature     | -25°C to +55°C  |
| Switching capacity      | 1200 VA (resistive load)  |
| Contact fuse            | 6.3 A fast-acting or 4 A flow-acting  |
| Operating voltages      | 24 V AC/DC (electronic fuse)<br>110, 230 V AC (galvanic isolation/ transformer)   |
| Power consumption       | 24 V AC: approx. 5 V A, 24 V DC: 3 W, 110/230 V AC: 3.7 V A   |
| Pick-up/reverse delay   | <50 ms / <30 ms (24 V AC <50 ms) recovery time <0.5 s   |
| Contact rating (max.)   | 5 A, 240 V AC, 24 V AC/DC, AC15 230 V/5 A, DC13 24 V/5 A  |
| Contact rating (min.)   | 6 mA  |

SAFE 4 is an emergency off and safety door relay for one and two-channel applications up to Cat. 4/PLe.

SAFE 4: With monitoring of the start button

SAFE 4.1: Without monitoring of the start button.

This enables automatic start (attention: not for emergency off!)

EN ISO 13849-1: PLe, Cat. 4 | MTTFd: 154 years /high | DC: 99 % /high | CCF: met

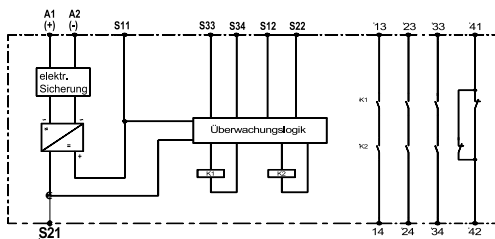

|                    | SAFE 4         |                |                | SAFE 4.1       |                |                |
|--------------------|----------------|----------------|----------------|----------------|----------------|----------------|
|                    | 24 V AC/DC     | 110 V AC       | 230 V AC       | 24 V AC/DC     | 110 V AC       | 230 V AC       |
| Operating voltages |                |                |                |                |                |                |
| Art. no.           | 46353<br>45042 | 46355<br>45045 | 46357<br>45255 | 46354<br>45046 | 46356<br>45052 | 46358<br>45054 |

## SAFE 4.1 eco



Up to 40 % less energy consumption.

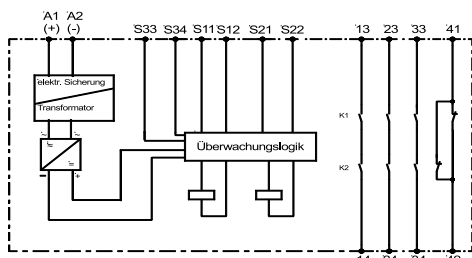

|                         |   |
|-------------------------|---|
| Application             | Pins and functions compatible with SAFE 4.1, very short reverse delay   |
| Approval                | TÜV, UL, C-UL   |
| Contacts                | 3 normally open, 1 normally closed  |
| Special characteristics | Visual switching status indication and mains control via LED<br>Cross-circuit protection - monitoring of the START button |
| LED                     | Mains, channel 1 and channel 2  |
| Ambient temperature     | -25°C to +55°C  |
| Switching capacity      | 1200 VA (resistive load)  |
| Contact fuse            | 6.3 A fast-acting or 4 A flow-acting  |
| Operating voltages      | 24 V AC/DC (electronic fuse)  |
| Power consumption       | 24 V DC: 1.5 W / AC: 3.6 V A  |
| Pick-up/reverse delay   | 200 ms / <10 ms / recovery time <0.5 s  |
| Contact rating (max.)   | 5 A, 240 V AC, 24 V AC/DC   |
| Contact rating (min.)   | 10 mA   |

This variant is compatible with the SAFE 4.1 in terms of pins and functions.

SAFE 4 eco devices are characterised by their low power consumption and very short reverse delay (<10 ms). They are also available in AC variants.

EN ISO 13849: PLe, Cat. 4 | MTTFd: 910 years /high /DC=99 % /high | CCF: met  
Supplementary information as per EN 61508: SIL3 | PFH:  $2.32 \cdot 10^{-9} /h$  | PFD:  $7.3 \cdot 10^{-6} /h$  | SFF=99 % | HFT: 1

|          |       |
|----------|-------|
| Art. no. | 45069 |
|----------|-------|

## SAFE 4.2 eco

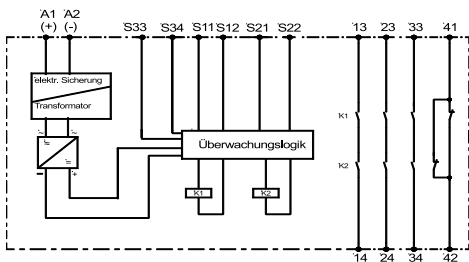

|                         |  |
|-------------------------|--|
| Application             | Optional monitored or non-monitored start, very short reverse delay  |
| Approval                | TÜV, UL, C-UL  |
| Contacts                | 3 normally open, 1 normally closed   |
| Special characteristics | Visual switching status indication and mains control via LED<br>Cross-circuit protection - with and without monitoring of the START button |
| LED                     | Mains, channel 1 and channel 2   |
| Ambient temperature     | -25°C to +55°C   |
| Switching capacity      | 1200 VA (resistive load)   |
| Contact fuse            | 6.3 A fast-acting or 4 A flow-acting   |
| Operating voltages      | 24 V AC/DC (electronic fuse)<br>115, 230 V AC (galvanic isolation/transformer)   |
| Power consumption       | 24 V DC: 1.5 W / AC: 3.6 V A   |
| Pick-up/reverse delay   | 200 ms / <10 ms / recovery time <0.5 s   |
| Contact rating (max.)   | 5 A, 240 V AC, 24 V AC/DC  |
| Contact rating (min.)   | 10 mA  |

SAFE 4.2 eco: Optional choice (depending on wiring) between monitored and non-monitored start (manual/automatic)  
 EN ISO 13849: PLe, Cat. 4 | MTTFd: 910 years/high/DC=99%/high | CCF: met  
 Supplementary information as per EN 61508: SIL3 | PFH:  $2.32 \cdot 10^{-9} / h$  | PFD:  $7.3 \cdot 10^{-6} / h$  | SFF=99% | HFT: 1

|                    |            |          |          |
|--------------------|------------|----------|----------|
| Operating voltages | 24 V AC/DC | 115 V AC | 230 V AC |
| Art. no.           | 45317      | 45318    | 45319    |

## SAFE 4.3 eco

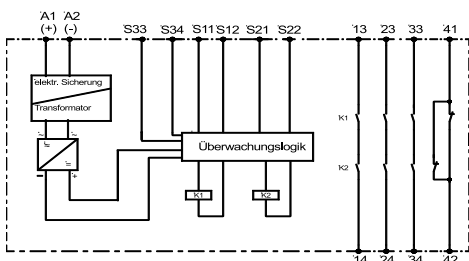

|                         |  |
|-------------------------|--|
| Application             | For safety proximity switches with reed contacts (1 N/O / 1 N/C), very short reverse delay   |
| Approval                | TÜV, UL, C-UL  |
| Contacts                | 3 normally open, 1 normally closed   |
| Special characteristics | Visual switching status indication and mains control via LED<br>Cross-circuit protection, antivalent contacts of the release element - with and without monitoring of the START button |
| LED                     | Mains, channel 1 and channel 2   |
| Ambient temperature     | -25°C to +55°C   |
| Switching capacity      | 1200 VA (resistive load)   |
| Contact fuse            | 6.3 A fast-acting or 4 A flow-acting   |
| Operating voltages      | 24 V AC/DC (electronic fuse)<br>115, 230 V AC (galvanic isolation/transformer)<br>Antivalent switching contact (including reed contacts)   |
| Power consumption       | 24 V DC: 1.5 W / AC: 3.6 V A   |
| Pick-up/reverse delay   | 200 ms / <10 ms / recovery time <0.5 s   |
| Contact rating (max.)   | 5 A, 240 V AC, 24 V AC/DC  |
| Contact rating (min.)   | 10 mA  |

SAFE 4.3 eco: Specifically designed for safety door applications with reed contacts (sensor current < 10 mA), consisting of one normally open and one normally closed contact, as well as optional start (manual/automatic).

EN ISO 13849: PLe, Cat. 4 | MTTFd: 910 years/high/DC=99%/high | CCF: met  
 Supplementary information as per EN 61508: SIL3 | PFH:  $2.32 \cdot 10^{-9} / h$  | PFD:  $7.3 \cdot 10^{-6} / h$  | SFF=99% | HFT: 1

|                    |            |          |          |
|--------------------|------------|----------|----------|
| Operating voltages | 24 V AC/DC | 115 V AC | 230 V AC |
| Art. no.           | 45320      | 45321    | 45322    |

# 1 | Emergency stop circuits and safety door monitoring contacts

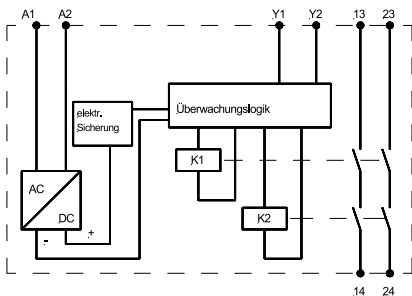

## SAFE 5 / SAFE 5.1

|                         |   |
|-------------------------|---|
| Application             | One and two-channel switching technology for emergency off switches or limit switches for sliding safety guards, low-cost, up to Cat. 3/PLe, small design |
| Approval                | TÜV, UL, C-UL   |
| Contacts                | 2 normally open   |
| Special characteristics | Visual switching status indication and mains control via LED<br>With (SAFE 5) and without (SAFE 5.1) monitoring of the START button                       |
| LED                     | Mains, channel 1 and channel 2  |
| Ambient temperature     | -25°C to +55°C  |
| Switching capacity      | 1500 VA (resistive load)  |
| Contact fuse            | 6.3 A fast-acting or 4 A flow-acting  |
| Operating voltages      | 24 V AC/DC (+10 - 15 %) electronic fuse   |
| Power consumption       | Approx. 1.6 V A / 1.6 W   |
| Pick-up/reverse delay   | <50 ms / <80 ms (AC), <50 ms (DC)   |
| Contact rating (max.)   | 6 A, 250 V AC, 24 V DC  |
| Contact rating (min.)   | 6 mA  |

Emergency off and safety door relay up to Cat. 3 / PLe for one and two-channel applications.

SAFE 5: With monitoring of the start button (manual start)

SAFE 5.1: Without monitoring of the start button (automatic start)

EN ISO 13849-1: PLe, Cat. 3 (\*\*\*)see product navigator page 6-7) | MTTFd: 71 years / high  
DC: 90 % / medium | CCF: met

|          | SAFE 5 | SAFE 5.1 |
|----------|--------|----------|
| Art. no. | 45228  | 45232    |

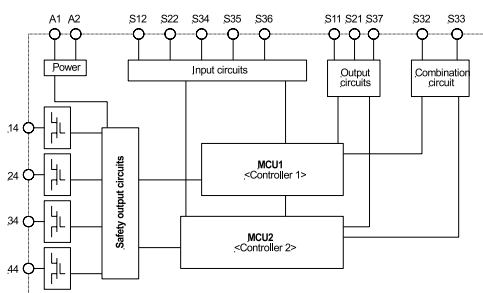

## SAFE C1

|                         |  |
|-------------------------|--|
| Application             | With wear-free semiconductor outputs and logical connections   |
| Approval                | TÜV, UL, C-UL  |
| Contacts                | 4 safety semiconductor outputs (OSSD)  |
| Special characteristics | Visual switching status indication and mains control via LED<br>Wear-free semiconductor outputs, "AND", "OR" connection between multiple devices from the SAFE C family possible, autostart possible |
| LED                     | Mains, channel 1 and channel 2 + warning system  |
| Ambient temperature     | -25°C to +55°C   |
| Switching capacity      | Up to 43 W   |
| Contact fuse            | Short-circuit protected  |
| Operating voltages      | 24 V DC (+ 25 - 20 %)<br>Surge protection  |
| Power consumption       | Approx. 3 W  |
| Pick-up/reverse delay   | <70 ms / <30 ms  |
| Contact rating (max.)   | Sum current up to 1.8 A (individual or in total)   |
| Contact rating (min.)   | Unlimited  |

Emergency off and safety door relay with 4 semiconductor outputs (OSSD wear-free).

Optional manual or automatic start (with/without monitoring) of the START button and additional AND or OR functions that assume the function of the control relay.

Cross-circuit protection between the inputs and/or outputs.

EN ISO 13849: PLe, Cat. 4 | MTTFd: 163 years / high | DC: 99 %

Supplementary information as per EN 61508: SIL3 | PFH:  $2.87 \cdot 10^{-9} 1/h$  | PFD:  $2.01 \cdot 10^{-6} 1/h$  | SFF: 0.9573

|          |       |
|----------|-------|
| Art. no. | 45327 |
|----------|-------|

## SAFE FLEX



|                         |   |
|-------------------------|---|
| Application             | Safety relay with optional function variants  |
| Approval                | TÜV, UL, C-UL   |
| Contacts                | 2 normally open, 1 PLC output (PNP)   |
| Special characteristics | Visual switching status indication via LED, visual fault indication via LED, optional monitored and non-monitored start |
| LED                     | Mains, channel 1 IN / OUT, channel 2 IN / OUT, fault  |
| Ambient temperature     | -25°C to +55°C  |
| Switching capacity      | 1500 V A  |
| Contact fuse            | 6 A fast-acting or 4 A flow-acting  |
| Operating voltages      | 24 V DC (+ 20 – 25 %) surge protection  |
| Power consumption       | <3 W  |
| Pick-up/reverse delay   | Emergency off, non-contact safety device, two-hand, safety door guard <=30 ms   |
| Contact rating (max.)   | 6 A, 250 V AC, 250 V DC   |
| Contact rating (min.)   | 5 mA  |

The following functions are optionally available when wired accordingly:

- Emergency off safety relay Cat. 4
- Safety door guard cat. 4
- Two-hand relay type III c Cat. 4
- Relay for non-contact safety devices/light barriers, Cat. 4 and Cat. 2
- 1-pin safety devices with cycle-based monitoring via test output, Cat. 4
- Monitoring of movement direction through various tolerance ranges for monitoring synchronisation
- Changes to wiring during ongoing operation are recognised as a fault

EN ISO 13849: PLe, Cat. 4 | MTTFd: >100 years/high | DC: 99 % / high  
 Supplementary information as per EN 61508: SIL3 | PFH:  $2.15 \cdot 10^{-9} / h$  | SSF: 94.65 %

|          |       |
|----------|-------|
| Art. no. | 45332 |
|----------|-------|

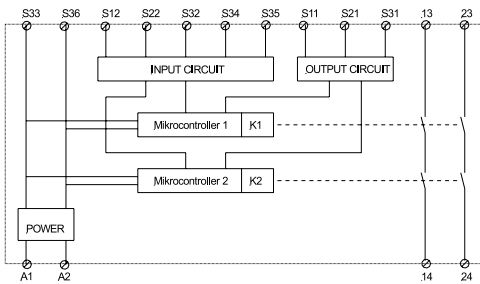

## SAFE 1 / SAFE 1.1



|                         |  |
|-------------------------|--|
| Application             | One and two-channel switching technology for emergency off switches or limit switches for safety guards, low-cost up to Cat. 3 / PLd, small design |
| Approval                | TÜV, UL, C-UL  |
| Contacts                | 3 normally open, 1 normally closed   |
| Special characteristics | Visual switching status indication and mains control via LED<br>With (SAFE 1.1) and without (SAFE 1) monitoring of the START button                |
| LED                     | Mains, channel 1 and channel 2   |
| Ambient temperature     | -25°C to +55°C   |
| Switching capacity      | 1250 VA (resistive load)   |
| Contact fuse            | 6.3 A fast-acting or 4 A flow-acting   |
| Operating voltages      | 24 V ACDC (electronic fuse)  |
| Power consumption       | Approx. 2.5 V A / 2.5 W  |
| Pick-up/reverse delay   | <50 ms / <100 ms   |
| Contact rating (max.)   | 5 A, 250 V AC, 24 V DC   |
| Contact rating (min.)   | 1 mA   |

Emergency off and safety door relay up to Cat. 3 / PLd in small design.

One and two-channel applications possible.

Also for AC supply.

EN ISO 13849-1: PLd, Cat. 3 (\*\*\*)see product navigator page 6) | MTTFd: 37.57 years / high  
 DC: 90 % / medium | CCF: met

|          | SAFE 1 | SAFE 1.1 |
|----------|--------|----------|
| Art. no. | 45037  | 45036    |

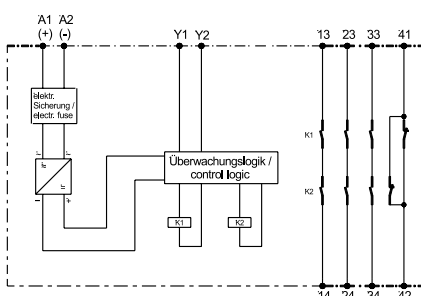

# 1 | Emergency stop circuits and safety door monitoring contacts

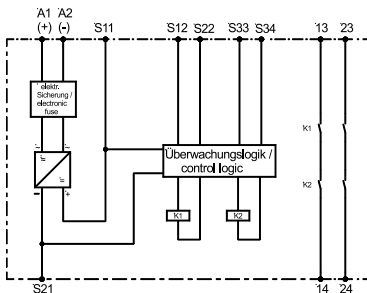

## SAFE 2 / SAFE 2.1

|                         |   |
|-------------------------|---|
| Application             | One and two-channel switching technology for emergency off switches or limit switches for safety guards, small design               |
| Approval                | TÜV, UL, C-UL   |
| Contacts                | 2 normally open   |
| Special characteristics | Visual switching status indication and mains control via LED<br>With (SAFE 2) and without (SAFE 2.1) monitoring of the START button |
| LED                     | Mains, channel 1 and channel 2  |
| Ambient temperature     | -25°C to +55°C  |
| Switching capacity      | 1500 VA (resistive load)  |
| Contact fuse            | 6.3 A fast-acting or 4 A flow-acting  |
| Operating voltages      | 24 V AC/DC (electronic fuse)  |
| Power consumption       | Approx. 2.5 V A / 2.5 W   |
| Pick-up/reverse delay   | <50 ms / <30 ms   |
| Contact rating (max.)   | 6 A, 250 V AC, 24 V DC  |
| Contact rating (min.)   | 6 mA  |

Emergency off and safety door relay up to Cat. 4 / PLe for one and two-channel applications.

SAFE 2: With monitoring of the start button (manual start)

SAFE 2.1: Without monitoring of the start button (automatic start)

EN ISO 13849-1: PLe, Cat. 4 | MTTFd: 69 years / high | DC: 99 % / high | CCF: met

|          | SAFE 2 | SAFE 2.1 |
|----------|--------|----------|
| Art. no. | 45038  | 45039    |

## SAFE S.6

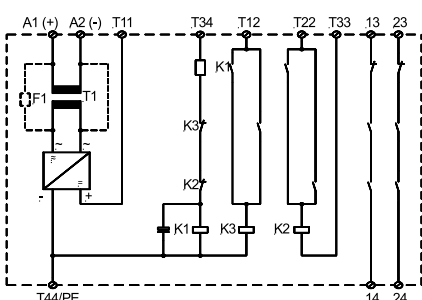

|                         |   |
|-------------------------|---|
| Application             | One and two-channel switching technology for emergency off switches or limit switches for safety guards, robust design  |
| Approval                | TÜV, UL, C-UL   |
| Contacts                | 2 normally open   |
| Special characteristics | Visual switching status indication and mains control via LED<br>Optional cross-circuit protection   |
| LED                     | Mains, channel 1 and channel 2  |
| Ambient temperature     | -25°C to +55°C  |
| Switching capacity      | 1380 VA (resistive load)  |
| Contact fuse            | 6 A fast-acting or 4 A flow-acting  |
| Operating voltages      | 24 V AC/DC (no galvanic isolation/with fuse),<br>24 V DC (no galvanic isolation/electronic fuse),<br>24, 48, 110-127, 230 V AC (galvanic isolation/transformer) |
| Power consumption       | Approx. 3 V A   |
| Pick-up/reverse delay   | <150 ms / <30 ms  |
| Contact rating (max.)   | 6 A, 250 V AC, 24 V DC  |
| Contact rating (min.)   | 100 mA <sup>(1)</sup>   |

The robust emergency off and safety door guard safety relay is available in many voltage variants.

EN ISO 13849-1: Pld / e, Cat. 3 / 4 (depending on wiring) | MTTFd: 74.15 years / high

DC: Cat. 3: 90 % / medium, Cat. 4: 99 % / high | CCF: met

| Operating voltages | 24 V AC/DC | 48 V AC | 110 -127 V AC | 230 VAC |
|--------------------|------------|---------|---------------|---------|
| Art. no.           | 45244      | 45035   | 45245         | 45246   |

**NEW**

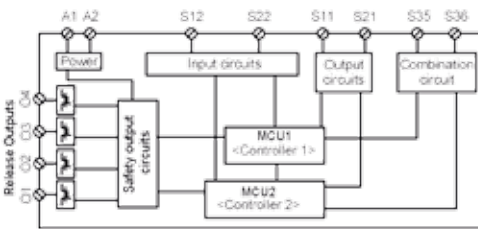

## SAFE G1

|                                 |  |
|---------------------------------|--|
| Application                     | Multi-functional safety relay with optional properties   |
| Approval                        | SIL3, SIL <sub>cat</sub> 3, PLe, Cat4 possible, EN ISO 13849, EN 62061, EN 61508, MTTFd=2403a; PFH=1.89 E-09 1/h;  |
| Outputs                         | 4 OSSDs (secure semiconductor outputs), short-circuit protected<br>• 3 normally open direct, 1 normally closed direct<br><br>• Emergency off and safety door guard<br>- 2 channels, 4-wire   2 channels, 3-wire   1 channel, 2-wire<br><br>• Non-contact safety device<br>- Type 4<br>- Type 2<br><br>• Safety mat |
| Functions, optional             |  |
| Start behaviour                 | Optionally with automatic or manual start (monitored)  |
| Special characteristics         | Visual status indication via LED<br>Visual fault indication via LED (fault code)<br>Monitoring of external fuses   |
| Ambient temperature             | 0°C to +55°C   |
| Switching capacity              | 4x 400 mA, 24 V DC   |
| Operating voltages              | 24 V DC ± 20 %   |
| Power consumption               | Approx. 3 W (idle)   |
| Reverse delay (Direct contacts) | 20 ms<br>25 ms (non-contact safety device type 2)  |
| Housing (W x H x D)             | 18 x 90 x 58 mm  |

The SAFE G1 is an inexpensive variant with a fixed output configuration of 3 normally opened/1 normally closed contacts.

|          |       |
|----------|-------|
| Art. no. | 45337 |
|----------|-------|

**NEW**

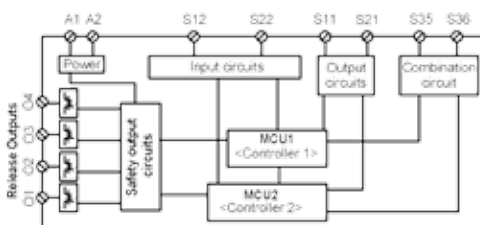

## SAFE G2

|                                 |  |
|---------------------------------|--|
| Application                     | Multi-functional safety relay with optional properties   |
| Approval                        | SIL3, SIL <sub>cat</sub> 3, PLe, Cat4 possible, EN ISO 13849, EN 62061, EN 61508, MTTFd=2403a; PFH=1.89 E-09 1/h;  |
| Outputs                         | 4 OSSDs (secure semiconductor outputs), short-circuit protected<br>• 4 normally open direct<br><br>• Emergency off and safety door guard<br>- 2 channels, 4-wire   2 channels, 3-wire   1 channel, 2-wire<br><br>• Non-contact safety device<br>- Type 4<br>- Type 2<br><br>• Safety mat |
| Functions, optional             |  |
| Start behaviour                 | Optionally with automatic or manual start (monitored)  |
| Special characteristics         | Visual status indication via LED<br>Visual fault indication via LED (fault code)<br>Monitoring of external fuses   |
| Ambient temperature             | 0°C to +55°C   |
| Switching capacity              | 4x 400 mA, 24 V DC   |
| Operating voltages              | 24 V DC ± 20 %   |
| Power consumption               | Approx. 3 W (idle)   |
| Reverse delay (Direct contacts) | 20 ms<br>25 ms (non-contact safety device type 2)  |
| Housing (W x H x D)             | 18 x 90 x 58 mm  |

The SAFE G2 is an inexpensive variant with a fixed output configuration of 4 normally opened contacts.

|          |       |
|----------|-------|
| Art. no. | 45338 |
|----------|-------|

# 1 | Emergency stop circuits and safety door monitoring contacts

**NEW**

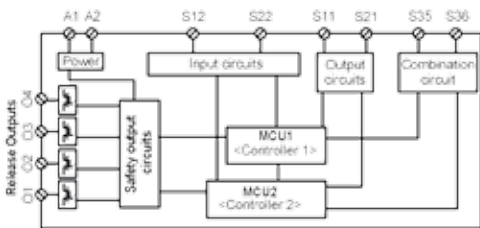

## SAFE GT

|                                 |   |
|---------------------------------|---|
| Application                     | Multi-functional safety relay with optional properties, optional output configuration and adjustable delay time   |
| Approval                        | SIL3, SIL <sub>cat</sub> 3, Ple, Cat4 possible, EN ISO 13849, EN 62061, EN 61508, MTTFd=2403a; PFH=1.89 E-09 1/h;   |
| Outputs                         | 4 OSSDs (secure semiconductor outputs), short-circuit protected, optional<br><ul style="list-style-type: none"> <li>• 3 normally open direct, 1 normally closed direct</li> <li>• 4 normally open direct</li> <li>• 2 normally open direct, 2 normally open del.; adjustable 0.1 s to 30 s</li> </ul>   |
| Functions, optional             | <ul style="list-style-type: none"> <li>• Emergency off and safety door guard <ul style="list-style-type: none"> <li>- 2 channels, 4-wire   2 channels, 3-wire   1 channel, 2-wire</li> </ul> </li> <li>• Non-contact safety device <ul style="list-style-type: none"> <li>- Type 4</li> <li>- Type 2</li> </ul> </li> <li>• Safety mat</li> </ul> |
| Start behaviour                 | Optionally with automatic or manual start (monitored)   |
| Special characteristics         | Visual status indication via LED, visual fault indication via LED (fault code), monitoring of external fuses  |
| Ambient temperature             | 0°C to +55°C  |
| Switching capacity              | 4x 400 mA, 24 V DC  |
| Operating voltages              | 24 V DC ± 20 %  |
| Power consumption               | Approx. 3 W (idle)  |
| Reverse delay (Direct contacts) | 20 ms<br>25 ms (non-contact safety device type 2)   |
| Housing (W x H x D)             | 18 x 90 x 58 mm   |

The SAFE GT is the variant with a hex switch, which can be used to set numerous options for the output configuration. Various delay times from 0.3 - 30 s can be set.

|          |       |
|----------|-------|
| Art. no. | 45336 |
|----------|-------|

**NEW**

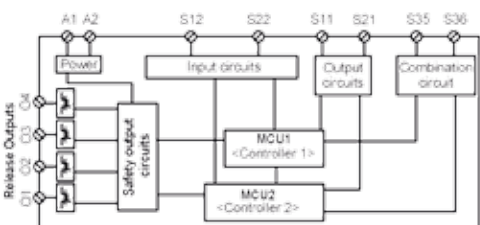

## SAFE GL

|                                 |   |
|---------------------------------|---|
| Application                     | Multi-functional safety relay with optional properties for lift applications  |
| Approval                        | SIL3, SIL <sub>cat</sub> 3, Ple, Cat4 possible, EN81-20, EN81-50, EN ISO 13849, EN 61508, EN 62061, MTTFd=1268a; PFH=3.58 E-09 1/h;   |
| Outputs                         | 4 OSSDs (secure semiconductor outputs), short-circuit protected<br><ul style="list-style-type: none"> <li>• 3 normally open direct, 1 normally closed direct</li> </ul>   |
| Functions, optional             | <ul style="list-style-type: none"> <li>• Emergency off and safety door guard <ul style="list-style-type: none"> <li>- 2 channels, 4-wire   2 channels, 3-wire   1 channel, 2-wire</li> </ul> </li> <li>• Non-contact safety device <ul style="list-style-type: none"> <li>- Type 4</li> <li>- Type 2</li> </ul> </li> <li>• Safety mat</li> </ul> |
| Start behaviour                 | Optionally with automatic or manual start (monitored)   |
| Special characteristics         | Visual status indication via LED, visual fault indication via LED (fault code), monitoring of external fuses  |
| Ambient temperature             | 0°C to +65°C  |
| Switching capacity              | 4x 400 mA, 24 V DC  |
| Operating voltages              | 24 V DC ± 20 %  |
| Power consumption               | Approx. 3 W (idle)  |
| Reverse delay (Direct contacts) | 20 ms<br>25 ms (non-contact safety device type 2)   |
| Housing (W x H x D)             | 18 x 90 x 58 mm   |

The SAFE GL is the variant with lift approval according to EN 81.

|          |       |
|----------|-------|
| Art. no. | 45335 |
|----------|-------|

## 2 | Emergency stop and safety door applications with switching delay



### SAFET...

|                         |   |
|-------------------------|---|
| Application             | With direct and release-delayed release circuits  |
| Approval                | TÜV, UL, C-UL   |
| Contacts                | 2 normally open direct, 2 normally open with pick-up delay, 1 normally closed   |
| Special characteristics | Cross-circuit protection or 1-channel switching<br>Time domain 0.05 s – 600 s in 64 stages<br>Start automatic or manual (monitored) |
| LED                     | Mains, channel 1 and 2, channel 1 and 2 delayed   |
| Ambient temperature     | -25°C to +55°C  |
| Switching capacity      | 1500 VA (resistive load)  |
| Contact fuse            | 3.6 A   |
| Operating voltages      | 24 V AC/DC (+ 25 - 20 %) (electronic fuse)  |
| Power consumption       | Approx. 4.8 W   |
| Pick-up/reverse delay   | <400 ms / <30 ms / setting  |
| Contact rating (max.)   | 6 A , 250 V AC, 24 V DC   |
| Contact rating (min.)   | 6 mA  |

Emergency off and safety door device with a release delay that can be configured over a wide range. The recovery time after applying the supply voltage is <0.95 s.

**SAFETN:** After pressing the trigger element (e.g. emergency off switch), synchronisation begins. This takes 1 s. For two-channel applications, both channels have to be actuated within this time. After this time until the end of the timer period, the trigger element may no longer be actuated (e.g. taken back). A defect/loose contact on the button or connection can be identified immediately. **SAFETA:** The trigger element can be actuated during the entire timer period (e.g. taken back). The synchronisation period is 3 s. Restart after the timer period is up. **SAFETR:** Variant that can be retriggered. The device can be retriggered (restarted) during the timer period, e.g. by taking back the emergency off switch. The synchronisation period is 3 s. **SAFETU:** The trigger element can be actuated during the entire timer period (e.g. taken back). There is no synchronisation period (non-stop synchronisation). Restart after the timer period is up.

EN IS 3849: PLe, Cat. 4 | MTTFd: >100 years | DC: 99 %

Supplementary information as per EN 61508: PFH:  $3.4 \cdot 10^{-9} \frac{1}{h}$ , PFD:  $9.32 \cdot 10^{-6} \frac{1}{h}$  | SFF: 94 %

|          | SAFETN | SAFETA | SAFETR | SAFETU |
|----------|--------|--------|--------|--------|
| Art. no. | 45024  | 45025  | 45209  | 45026  |

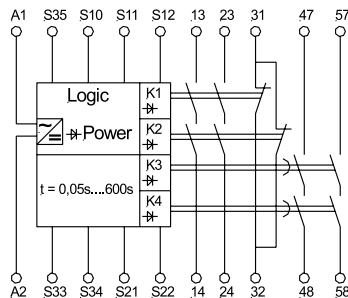

### SAFET ON



|                         |   |
|-------------------------|---|
| Application             | For safety doors with magnetic locking  |
| Approval                | TÜV, UL, C-UL   |
| Contacts                | 2 normally open, 2 normally open with pick-up delay, 1 normally closed  |
| Special characteristics | Cross-circuit protection or 1-channel<br>Time domain 0.05 s – 600 s in 64 stages<br>Start automatic or manual |
| LED                     | Mains, channel 1 and 2, channel 1 and 2 with pick-up delay  |
| Ambient temperature     | -25°C to +55°C  |
| Switching capacity      | 1500 VA (resistive load)  |
| Contact fuse            | 3.6 A   |
| Operating voltages      | 24 V AC/DC (+ 25 - 20 %) (electronic fuse)  |
| Power consumption       | Approx. 4.8 W   |
| Pick-up/reverse delay   | 400 ms / 30 ms  |
| Contact rating (max.)   | 6 A, 250 V AC, 24 V DC  |
| Contact rating (min.)   | 6 mA  |

The device is designed for controlling safety doors with magnetic locking.

The time for releasing the safety doors can be set variably.

EN ISO 13849: PLe, Cat. 4 | MTTFd: >100 years | DC: 99 %

Supplementary information as per EN 61508: PFH:  $3.4 \cdot 10^{-9} \frac{1}{h}$ , PFD:  $9.32 \cdot 10^{-6} \frac{1}{h}$  | SFF: 94 %

|          |       |
|----------|-------|
| Art. no. | 45215 |
|----------|-------|

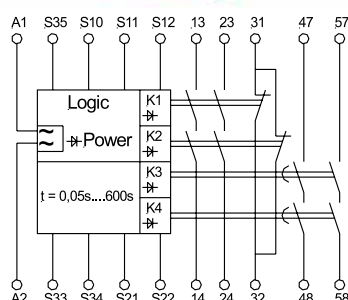

## 2 | Emergency stop and safety door applications with switching delay

NEW

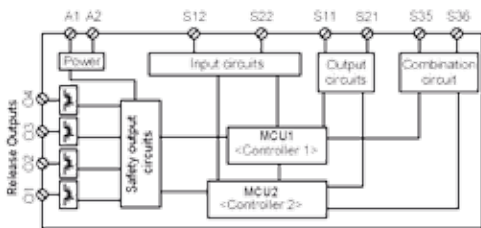

### SAFE GT

|                                 |   |
|---------------------------------|---|
| Application                     | Multi-functional safety relay with optional properties, optional output configuration and adjustable delay time   |
| Approval                        | SIL3, SIL <sub>cat</sub> 3, PLe, Cat4 possible, EN ISO 13849, EN 62061, EN 61508, MTTFd=2403a; PFH=1.89 E-09 1/h;   |
| Outputs                         | 4 OSSDs (secure semiconductor outputs), short-circuit protected, optional<br>• 3 normally open direct, 1 normally closed direct<br>• 4 normally open direct<br>• 2 normally open direct, 2 normally open del.; adjustable 0.1 s to 30 s |
| Functions, optional             | • Emergency off and safety door guard<br>- 2 channels, 4-wire   2 channels, 3-wire   1 channel, 2-wire<br>• Non-contact safety device<br>- Type 4<br>- Type 2<br>• Safety mat   |
| Start behaviour                 | Optionally with automatic or manual start (monitored)   |
| Special characteristics         | Visual status indication via LED, visual fault indication via LED (fault code), monitoring of external fuses  |
| Ambient temperature             | 0°C to +55°C  |
| Switching capacity              | 4x 400 mA, 24 V DC  |
| Operating voltages              | 24 V DC ± 20 %  |
| Power consumption               | Approx. 3 W (idle)  |
| Reverse delay (Direct contacts) | 20 ms<br>25 ms (non-contact safety device type 2)   |
| Housing (W x H x D)             | 18 x 90 x 58 mm   |

The SAFE GT is the variant with a hex switch, which can be used to set numerous options for the output configuration. Various delay times from 0.3 - 30 s can be set.

|          |       |
|----------|-------|
| Art. no. | 45336 |
|----------|-------|

### SAFE FLEXT (outlook)

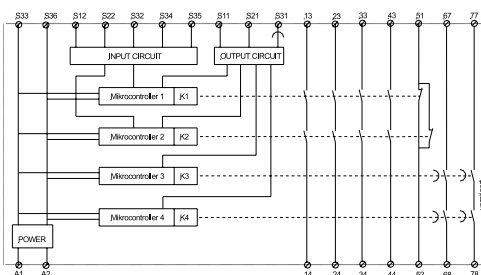

|                         |  |
|-------------------------|--|
| Application             | Safety relay for actuating e.g. proximity switches/distance sensors (ultrasounds, capacitive, inductive)                                     |
| Approval                | TÜV (UL, C-UL requested)   |
| Contacts                | 4 normally open (1x basic isolation), 2 normally open delayed, 1 normally closed (basic isolation), 1 semiconductor auxiliary output delayed |
| Special characteristics | Visual switching status indication via LED<br>Visual fault indication via LED, autostart possible  |
| LED                     | -  |
| Ambient temperature     | -25°C to +55°C   |
| Switching capacity      | -  |
| Contact fuse            | 6 A fast-acting or 4 A flow-acting   |
| Operating voltages      | 24 V DC (+ 20 - 25 %) surge protection   |
| Power consumption       | -  |
| Pick-up/reverse delay   | -  |
| Contact rating (max.)   | -  |
| Contact rating (min.)   | 5 mA   |

EN ISO 13849-1 / DIN EN 61508 / DIN EN 62061: parameters in preparation

|          |       |
|----------|-------|
| Art. no. | 4638X |
|----------|-------|

## SAFE CM

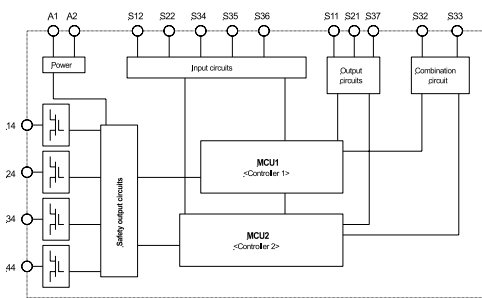

Application

For switching mats and strips with max. 500 ohms or a terminal resistance of 8.2 kOhms, with wear-free semiconductor outputs and logical connections

Approval

TÜV, UL, C-UL

Contacts

4 safety semiconductor outputs (OSSD)

Special characteristics

Visual switching status indication and mains control via LED  
Wear-free semiconductor outputs, "AND" connection between multiple devices from the SAFE C family possible, autostart possible

LED

Mains, channel 1 and channel 2

Ambient temperature

-25°C to +55°C

Switching capacity

Up to 43 W

Contact fuse

Short-circuit protected

Operating voltages

24 V DC (+ 25 - 20 %) surge protection

Power consumption

Approx. 3 W

Pick-up/reverse delay

<30 ms / <140 ms (1-channel <360 ms)

Contact rating (max.)

Sum current up to 1.8 A (individual or in total)

Contact rating (min.)

Unlimited

Safety relax for safety switch mats with wear-free semiconductor outputs (OSSD).

As a result, the device is suitable for applications with frequent actuations. Short-circuit mats with a terminal resistance of 8.2 kΩ and in line with the 4-wire principle are supported. Control relay functions can be assumed with the additional AND connection; optionally with manual or automatic start.

EN ISO 13849: PLe, Cat. 4 | MTTFd: 163 years / high | DC: 99 %

Supplementary information as per EN 61508: SIL3 | PFH:  $2.87 \cdot 10^{-9} / h$  | PFD:  $2.01 \cdot 10^{-6} / h$  | SFF: 0.9573

Art. no.

45071

## SAFE M / SAFE M.1

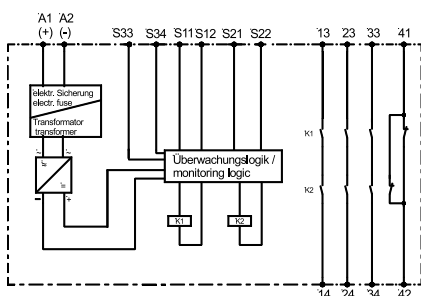

Application

Safety relax for safety switch mats and strips with a max. mat resistance of 200 ohms

Approval

TÜV, UL, C-UL

Contacts

3 normally open, 1 normally closed

Special characteristics

Visual switching status indication and mains control via LED  
Cross-circuit protection up to safety category 3  
With (SAFE M) and without (SAFE M.1) autostart

LED

Mains, channel 1 and channel 2

Ambient temperature

-25°C to +55°C

Switching capacity

1200 VA (resistive load)

Contact fuse

6.3 A fast-acting or 4 A flow-acting

Operating voltages

24 V AC/DC (electronic fuse)  
SAFE M: 115 V AC (galvanic isolation / transformer)

Power consumption

24, 115 V AC: approx. 5 V A, 24 V DC: 3 W

Pick-up/reverse delay

<50 ms / <30 ms (24 V AC <50 ms)

Contact rating (max.)

5 A, 240 V AC, 24 V DC

Contact rating (min.)

6 mA

In addition to DC supply, the mat device for 4-wire mats in accordance with the short-circuit principle is also available with AC supply.

EN ISO 13849-1: PLe, Cat. 3 | MTTFd: 73.21 years / high | DC: 90 % / medium | CCF: met

Supplementary information as per EN 61508: PFH:  $5.81 \cdot 10^{-9} / h$  | SSF: 99 %

Operating voltages

SAFE M

SAFE M.1

24 V AC/DC

115 V AC

24 V AC/DC

Art. no.

46365

46366

46367

45029

45240

45034

# 3 | Safety switch mats and safety edges

## NEW DESIGN

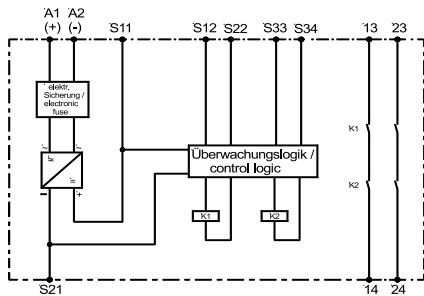

## SAFE 2.2

|                         |   |
|-------------------------|---|
| Application             | Safety relay for safety switch mats and strips for mats with short-circuit principle  |
| Approval                | TÜV, UL, C-UL   |
| Contacts                | 2 normally open   |
| Special characteristics | Visual switching status indication and mains control via LED<br>Up to safety category 4, for 2-channel circuit with cross-circuit protection and without monitoring of the START button |
| LED                     | Mains, channel 1 and channel 2  |
| Ambient temperature     | -25°C to +55°C  |
| Switching capacity      | 1500 VA (resistive load)  |
| Contact fuse            | 6.3 A fast-acting or 4 A flow-acting  |
| Operating voltages      | 24 V AC/DC (electronic fuse)  |
| Power consumption       | Approx. 2.5 V A / 2.5 W   |
| Pick-up/reverse delay   | <50 ms / <30 ms   |
| Contact rating (max.)   | 6 A, 250 V AC, 24 V DC  |
| Contact rating (min.)   | 1 mA  |

Safety relay for safety switch mats with wear-free semiconductor outputs in a space-saving housing. Short-circuit mats in line with the 4-wire principle are supported.

EN ISO 13849-1: PL<sub>e</sub>, Cat. 4 | MTTFd: 69 years / high | DC: 99 % / high | CCF: met

|          |       |
|----------|-------|
| Art. no. | 46387 |
|----------|-------|

## NEW

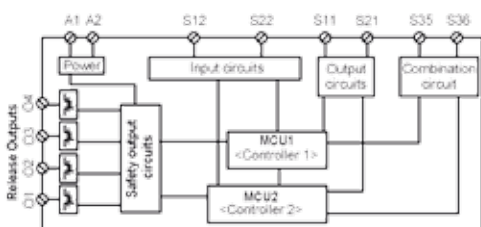

## SAFE G1

|                                 |  |
|---------------------------------|--|
| Application                     | Multi-functional safety relay with optional properties   |
| Approval                        | SIL3, SIL <sub>cl</sub> 3, PL <sub>e</sub> , Cat4 possible,<br>EN ISO 13849, EN 62061, EN 61508,<br>MTTFd=2403a; PFH=1.89 E-09 1/h;  |
| Outputs                         | 4 OSSDs (secure semiconductor outputs), short-circuit protected<br>• 3 normally open direct, 1 normally closed direct<br>• Emergency off and safety door guard<br>- 2 channels, 4-wire   2 channels, 3-wire   1 channel, 2-wire<br>• Non-contact safety device<br>- Type 4<br>- Type 2<br>• Safety mat |
| Functions, optional             |  |
| Start behaviour                 | Optionally with automatic or manual start (monitored)  |
| Special characteristics         | Visual status indication via LED<br>Visual fault indication via LED (fault code)<br>Monitoring of external fuses   |
| Ambient temperature             | 0°C to +55°C   |
| Switching capacity              | 4x 400 mA, 24 V DC   |
| Operating voltages              | 24 V DC ± 20 %   |
| Power consumption               | Approx. 3 W (idle)   |
| Reverse delay (Direct contacts) | 20 ms<br>25 ms (non-contact safety device type 2)  |
| Housing (W x H x D)             | 18 x 90 x 58 mm  |

The SAFE G1 is an inexpensive variant with a fixed output configuration of 3 normally opened/1 normally closed contacts.

|          |       |
|----------|-------|
| Art. no. | 45337 |
|----------|-------|

**NEW**

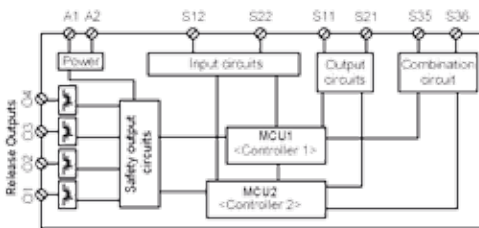

## SAFE G2

|                                 |  |
|---------------------------------|--|
| Application                     | Multi-functional safety relay with optional properties   |
| Approval                        | SIL3, SIL <sub>o</sub> 3, PLe, Cat4 possible, EN ISO 13849, EN 62061, EN 61508, MTTFFd=2403a; PFH=1.89 E-09 1/h;   |
| Outputs                         | 4 OSSDs (secure semiconductor outputs), short-circuit protected<br>• 4 normally open direct<br><br>• Emergency off and safety door guard<br>- 2 channels, 4-wire   2 channels, 3-wire   1 channel, 2-wire<br>• Non-contact safety device<br>- Type 4<br>- Type 2<br>• Safety mat |
| Functions, optional             |  |
| Start behaviour                 | Optionally with automatic or manual start (monitored)  |
| Special characteristics         | Visual status indication via LED<br>Visual fault indication via LED (fault code)<br>Monitoring of external fuses   |
| Ambient temperature             | 0°C to +55°C   |
| Switching capacity              | 4x 400 mA, 24 V DC   |
| Operating voltages              | 24 V DC ± 20 %   |
| Power consumption               | Approx. 3 W (idle)   |
| Reverse delay (Direct contacts) | 20 ms<br>25 ms (non-contact safety device type 2)  |
| Housing (W x H x D)             | 18 x 90 x 58 mm  |

The SAFE G2 is an inexpensive variant with a fixed output configuration of 4 normally opened contacts.

|          |       |
|----------|-------|
| Art. no. | 45338 |
|----------|-------|

**NEW**

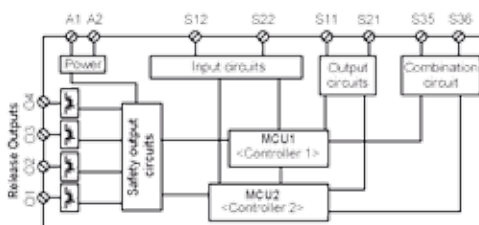

## SAFE GT

|                                 |  |
|---------------------------------|--|
| Application                     | Multi-functional safety relay with optional properties, optional output configuration and adjustable delay time  |
| Approval                        | SIL3, SIL <sub>o</sub> 3, PLe, Cat4 possible, EN ISO 13849, EN 62061, EN 61508, MTTFFd=2403a; PFH=1.89 E-09 1/h;   |
| Outputs                         | 4 OSSDs (secure semiconductor outputs), short-circuit protected, optional<br>• 3 normally open direct, 1 normally closed direct<br>• 4 normally open direct<br>• 2 normally open direct, 2 normally open del.; adjustable 0.1 s to 30 s<br><br>• Emergency off and safety door guard<br>- 2 channels, 4-wire   2 channels, 3-wire   1 channel, 2-wire<br>• Non-contact safety device<br>- Type 4<br>- Type 2<br>• Safety mat |
| Functions, optional             |  |
| Start behaviour                 | Optionally with automatic or manual start (monitored)  |
| Special characteristics         | Visual status indication via LED, visual fault indication via LED (fault code), monitoring of external fuses   |
| Ambient temperature             | 0°C to +55°C   |
| Switching capacity              | 4 x 400 mA, 24 V DC  |
| Operating voltages              | 24 V DC ± 20 %   |
| Power consumption               | Approx. 3 W (idle)   |
| Reverse delay (Direct contacts) | 20 ms<br>25 ms (non-contact safety device type 2)  |
| Housing (W x H x D)             | 18 x 90 x 58 mm  |

The SAFE GT is the variant with a hex switch, which can be used to set numerous options for the output configuration. Various delay times from 0.3 - 30 s can be set.

|          |       |
|----------|-------|
| Art. no. | 45336 |
|----------|-------|

# 3 | Safety switch mats and safety edges

**NEW**

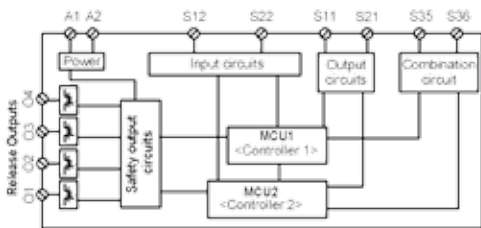

## SAFE GL

Application

Multi-functional safety relay with optional properties for lift applications

Approval

SIL3, SIL<sub>cat</sub>3, PLe, Cat4 possible, EN81-20, EN81-50, EN ISO 13849, EN 61508, EN 62061, MTTFD=1268a; PFH=3.58 E-09 1/h;

Outputs

4 OSSDs (secure semiconductor outputs), short-circuit protected  
 • 3 normally open direct, 1 normally closed direct

Functions, optional

- Emergency off and safety door guard
  - 2 channels, 4-wire | 2 channels, 3-wire | 1 channel, 2-wire
- Non-contact safety device
  - Type 4
  - Type 2
- Safety mat

Start behaviour

Optionally with automatic or manual start (monitored)

Special characteristics

Visual status indication via LED, visual fault indication via LED (fault code), monitoring of external fuses

Ambient temperature

0°C to +65°C

Switching capacity

4x 400 mA, 24 V DC

Operating voltages

24 V DC ± 20 %

Power consumption

Approx. 3 W (idle)

Reverse delay (Direct contacts)

20 ms  
 25 ms (non-contact safety device type 2)

Housing (W x H x D)

18 x 90 x 58 mm

The SAFE GL is the variant with lift approval according to EN 81.

Art. no.

45335

## SAFE L.2

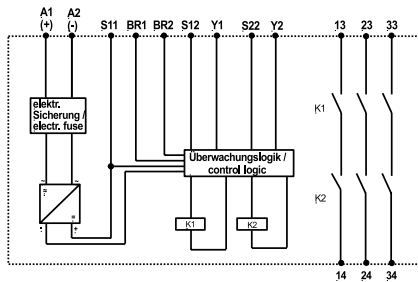

|                         |  |
|-------------------------|--|
| Application             | Safety relay<br>As a relay for safety light barrier/grid   |
| Approval                | TÜV, UL, C-UL  |
| Contacts                | 3 normally open  |
| Special characteristics | Visual switching status indication and mains control via LED<br>No cross-circuit protection<br>Monitoring of the START button via optional external bridge |
| LED                     | Mains, channel 1, channel 2 and restart lock   |
| Ambient temperature     | -25°C to +55°C   |
| Switching capacity      | 1500 VA (resistive load)   |
| Contact fuse            | 6 A fast-acting or 4 A flow-acting   |
| Operating voltages      | 24 V DC (electronic fuse)  |
| Power consumption       | Approx. 2.5 W  |
| Pick-up/reverse delay   | <50 ms / <30 ms  |
| Contact rating (max.)   | 6 A, 250 V AC, 24 V DC   |
| Contact rating (min.)   | 10 mA  |

Downstream device for safety light barriers with/without monitored start (manual or automatic start behaviour).

EN ISO 13849-1: PLe, Cat. 4 | MTTFd: 36 years / high | DC: 99 % / high | CCF: met

|          |       |
|----------|-------|
| Art. no. | 45058 |
|----------|-------|

## SAFE CL

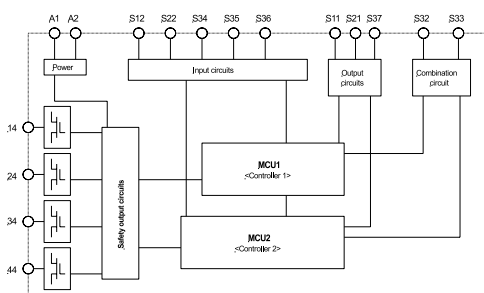

|                         |   |
|-------------------------|---|
| Application             | With semiconductor outputs and logical connections for Cat. 2 and Cat. 4  |
| Approval                | TÜV, UL, C-UL   |
| Contacts                | 4 safety semiconductor outputs (OSSD)<br>Visual switching status indication and mains control via LED<br>Wear-free semiconductor outputs, "AND" connection between multiple devices from the SAFE C family possible, autostart possible |
| Special characteristics | Mains, channel 1 and channel 2 + warning system   |
| LED                     | Mains, channel 1 and channel 2 + warning system   |
| Ambient temperature     | -25°C to +55°C  |
| Switching capacity      | Up to 43 W  |
| Contact fuse            | Short-circuit protected   |
| Operating voltages      | 24 V DC (+ 25 - 20 %) surge protection  |
| Power consumption       | Approx. 3 W   |
| Pick-up/reverse delay   | <70 ms / <30 ms   |
| Contact rating (max.)   | Sum current up to 1.8 A   |
| Contact rating (min.)   | Unlimited   |

Safety relays for safety light barriers Cat. 2 and Cat. 4. The device features 4 wear-free semiconductor outputs. As a result, the device is suitable for applications with frequent actuations. Control relay functions can be assumed with the additional AND connection; optionally with manual or automatic start.

EN ISO 13849: PLe, Cat. 4 | MTTFd: 163 years / high | DC: 99 %  
Supplementary information as per EN 61508: SIL3 | PFH:  $2.87 \cdot 10^{-9} 1/h$  | PFD:  $2.01 \cdot 10^{-6} 1/h$  | SFF: 0.9573

|          |       |
|----------|-------|
| Art. no. | 45328 |
|----------|-------|

# 4 | Non-contact safety devices



## SAFE FLEX

|                         |   |
|-------------------------|---|
| Application             | Safety relay with optional function variants  |
| Approval                | TÜV, UL, C-UL   |
| Contacts                | 2 normally open, 1 PLC output (PNP)   |
| Special characteristics | Visual switching status indication via LED, visual fault indication via LED, optional monitored and non-monitored start |
| LED                     | Mains, channel 1 IN / OUT, channel 2 IN / OUT, fault  |
| Ambient temperature     | -25°C to +55°C  |
| Switching capacity      | 1500 V A  |
| Contact fuse            | 6 A fast-acting or 4 A flow-acting  |
| Operating voltages      | 24 V DC (+ 20 - 25 %) surge protection  |
| Power consumption       | <3 W  |
| Pick-up/reverse delay   | Emergency off, non-contact safety device, two-hand, safety door guard <=30 ms   |
| Contact rating (max.)   | 6 A, 250 V AC, 250 V DC   |
| Contact rating (min.)   | 5 mA  |

The following functions are optionally available when wired accordingly:

- Emergency off safety relay Cat. 4
- Safety door guard cat. 4
- Two-hand relay type III c Cat. 4
- Relay for non-contact safety devices/light barriers, Cat. 4 and Cat. 2
- 1-pin safety devices with cycle-based monitoring via test output, Cat. 4
- Monitoring of movement direction through various tolerance ranges for monitoring synchronisation
- Changes to wiring during ongoing operation are recognised as a fault

EN ISO 13849: PLe, Cat. 4 | MTTFd: >100 years/high | DC: 99 % / high  
 Supplementary information as per EN 61508: SIL3 | PFH:  $2.15 \cdot 10^{-9} / h$  | SSF: 94.65 %

|          |       |
|----------|-------|
| Art. no. | 45332 |
|----------|-------|

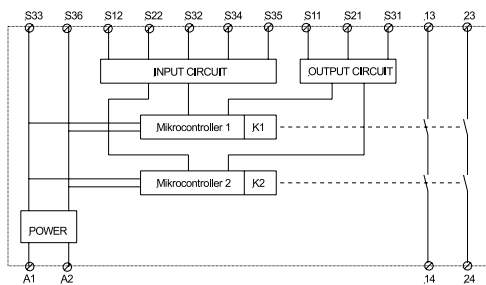

**NEW**



## SAFE FLEX L

|                         |   |
|-------------------------|---|
| Application             | Safety relay for actuating e.g. proximity switches/distance sensors (ultrasounds, capacitive, inductive)                |
| Approval                | TÜV, (UL, C-UL requested)   |
| Contacts                | 2 normally open, 1 PLC output   |
| Special characteristics | Visual switching status indication via LED, visual fault indication via LED, optional monitored and non-monitored start |
| LED                     | Mains, channel 1 IN / OUT, channel 2 IN / OUT, fault  |
| Ambient temperature     | -25°C to +55°C  |
| Switching capacity      | 1500 V A  |
| Contact fuse            | 6 A fast-acting or 4 A flow-acting  |
| Operating voltages      | 24 V DC (+ 20 - 25 %) surge protection  |
| Power consumption       | <3 W  |
| Pick-up/reverse delay   | Typical: <20 ms , during testing: <200 ms   |
| Contact rating (max.)   | 6 A, 250 V AC, 250 V DC   |
| Contact rating (min.)   | 5 mA  |

Safety relay for testable, non-contact safety devices.

Cascading is possible (reaction time of the entire cascade: 200 µs - 50 ms)

Up to two external non-contact safety devices can be supplied (max. power consumption of the non-contact safety devices: 50 mA)

EN ISO 13849: PLe, Cat. 4 | MTTFd: >100 years/high | DC: 99 % / high  
 Supplementary information as per EN 61508: SIL3 | PFH:  $2.15 \cdot 10^{-9} / h$  | SSF: 94.65 %

|          |       |
|----------|-------|
| Art. no. | 45364 |
|----------|-------|

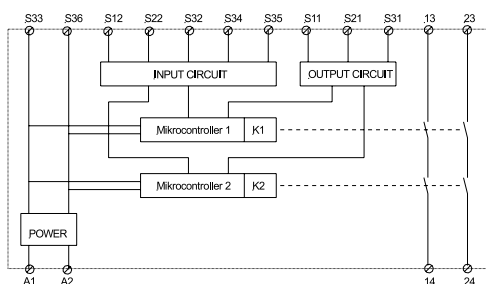

**NEW**

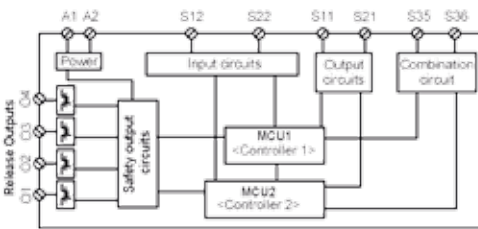

## SAFE G1

|                                 |  |
|---------------------------------|--|
| Application                     | Multi-functional safety relay with optional properties   |
| Approval                        | SIL3, SIL <sub>cat</sub> 3, PLe, Cat4 possible, EN ISO 13849, EN 62061, EN 61508, MTTFd=2403a; PFH=1.89 E-09 1/h;  |
| Outputs                         | 4 OSSDs (secure semiconductor outputs), short-circuit protected<br>• 3 normally open direct, 1 normally closed direct<br><br>• Emergency off and safety door guard<br>- 2 channels, 4-wire   2 channels, 3-wire   1 channel, 2-wire<br>• Non-contact safety device<br>- Type 4<br>- Type 2<br>• Safety mat |
| Functions, optional             |  |
| Start behaviour                 | Optionally with automatic or manual start (monitored)  |
| Special characteristics         | Visual status indication via LED<br>Visual fault indication via LED (fault code)<br>Monitoring of external fuses   |
| Ambient temperature             | 0°C to +55°C   |
| Switching capacity              | 4x 400 mA, 24 V DC   |
| Operating voltages              | 24 V DC ± 20 %   |
| Power consumption               | Approx. 3 W (idle)   |
| Reverse delay (Direct contacts) | 20 ms<br>25 ms (non-contact safety device type 2)  |
| Housing (W x H x D)             | 18 x 90 x 58 mm  |

The SAFE G1 is an inexpensive variant with a fixed output configuration of 3 normally opened/1 normally closed contacts.

|          |       |
|----------|-------|
| Art. no. | 45337 |
|----------|-------|

**NEW**

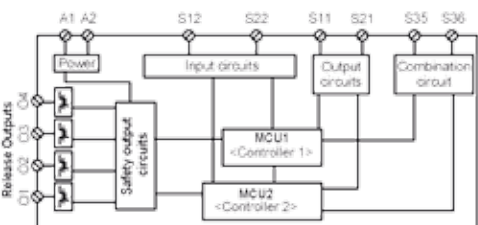

## SAFE G2

|                                 |  |
|---------------------------------|--|
| Application                     | Multi-functional safety relay with optional properties   |
| Approval                        | SIL3, SIL <sub>cat</sub> 3, PLe, Cat4 possible, EN ISO 13849, EN 62061, EN 61508, MTTFd=2403a; PFH=1.89 E-09 1/h;  |
| Outputs                         | 4 OSSDs (secure semiconductor outputs), short-circuit protected<br>• 4 normally open direct<br><br>• Emergency off and safety door guard<br>- 2 channels, 4-wire   2 channels, 3-wire   1 channel, 2-wire<br>• Non-contact safety device<br>- Type 4<br>- Type 2<br>• Safety mat |
| Functions, optional             |  |
| Start behaviour                 | Optionally with automatic or manual start (monitored)  |
| Special characteristics         | Visual status indication via LED<br>Visual fault indication via LED (fault code)<br>Monitoring of external fuses   |
| Ambient temperature             | 0°C to +55°C   |
| Switching capacity              | 4x 400 mA, 24 V DC   |
| Operating voltages              | 24 V DC ± 20 %   |
| Power consumption               | Approx. 3 W (idle)   |
| Reverse delay (Direct contacts) | 20 ms<br>25 ms (non-contact safety device type 2)  |
| Housing (W x H x D)             | 18 x 90 x 58 mm  |

The SAFE G2 is an inexpensive variant with a fixed output configuration of 4 normally opened contacts.

|          |       |
|----------|-------|
| Art. no. | 45338 |
|----------|-------|

# 4 | Non-contact safety devices

**NEW**

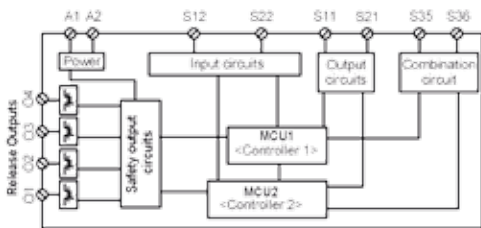

## SAFE GT

|                                 |   |
|---------------------------------|---|
| Application                     | Multi-functional safety relay with optional properties, optional output configuration and adjustable delay time   |
| Approval                        | SIL3, SIL <sub>cat</sub> 3, PLe, Cat4 possible, EN ISO 13849, EN 62061, EN 61508, MTTFd=2403a; PFH=1.89 E-09 1/h;   |
| Outputs                         | 4 OSSDs (secure semiconductor outputs), short-circuit protected, optional <ul style="list-style-type: none"> <li>• 3 normally open direct, 1 normally closed direct</li> <li>• 4 normally open direct</li> <li>• 2 normally open direct, 2 normally open del.; adjustable 0.1 s to 30 s</li> </ul>  |
| Functions, optional             | <ul style="list-style-type: none"> <li>• Emergency off and safety door guard                     <ul style="list-style-type: none"> <li>- 2 channels, 4-wire   2 channels, 3-wire   1 channel, 2-wire</li> </ul> </li> <li>• Non-contact safety device                     <ul style="list-style-type: none"> <li>- Type 4</li> <li>- Type 2</li> </ul> </li> <li>• Safety mat</li> </ul> |
| Start behaviour                 | Optionally with automatic or manual start (monitored)   |
| Special characteristics         | Visual status indication via LED, visual fault indication via LED (fault code), monitoring of external fuses  |
| Ambient temperature             | 0°C to +55°C  |
| Switching capacity              | 4x 400 mA, 24 V DC  |
| Operating voltages              | 24 V DC ±20 %   |
| Power consumption               | Approx. 3 W (idle)  |
| Reverse delay (Direct contacts) | 20 ms<br>25 ms (non-contact safety device type 2)   |
| Housing (W x H x D)             | 18 x 90 x 58 mm   |

The SAFE GT is the variant with a hex switch, which can be used to set numerous options for the output configuration. Various delay times from 0.3 - 30 s can be set.

|          |       |
|----------|-------|
| Art. no. | 45336 |
|----------|-------|

**NEW**

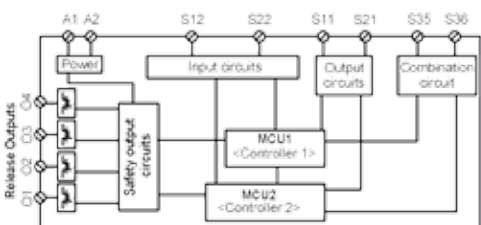

## SAFE GL

|                                 |   |
|---------------------------------|---|
| Application                     | Multi-functional safety relay with optional properties for lift applications  |
| Approval                        | SIL3, SIL <sub>cat</sub> 3, PLe, Cat4 possible, EN81-20, EN81-50, EN ISO 13849, EN 61508, EN 62061, MTTFd=1268a; PFH=3.58 E-09 1/h;   |
| Outputs                         | 4 OSSDs (secure semiconductor outputs), short-circuit protected <ul style="list-style-type: none"> <li>• 3 normally open direct, 1 normally closed direct</li> </ul>  |
| Functions, optional             | <ul style="list-style-type: none"> <li>• Emergency off and safety door guard                     <ul style="list-style-type: none"> <li>- 2 channels, 4-wire   2 channels, 3-wire   1 channel, 2-wire</li> </ul> </li> <li>• Non-contact safety device                     <ul style="list-style-type: none"> <li>- Type 4</li> <li>- Type 2</li> </ul> </li> <li>• Safety mat</li> </ul> |
| Start behaviour                 | Optionally with automatic or manual start (monitored)   |
| Special characteristics         | Visual status indication via LED, visual fault indication via LED (fault code), monitoring of external fuses  |
| Ambient temperature             | 0°C to +65°C  |
| Switching capacity              | 4x 400 mA, 24 V DC  |
| Operating voltages              | 24 V DC ±20 %   |
| Power consumption               | Approx. 3 W (idle)  |
| Reverse delay (Direct contacts) | 20 ms<br>25 ms (non-contact safety device type 2)   |
| Housing (W x H x D)             | 18 x 90 x 58 mm   |

The SAFE GL is the variant with lift approval according to EN 81.

|          |       |
|----------|-------|
| Art. no. | 45335 |
|----------|-------|

# 5 | Two-hand control circuits

## SAFE Z.2



|                         |  |
|-------------------------|--|
| Application             | For type I to III c with AC supply   |
| Approval                | TÜV, UL, C-UL  |
| Contacts                | 2 normally open, 1 normally closed, 1 PLC output   |
| Special characteristics | Visual switching status indication and mains control via LED<br>Two-hand control device acc. to ZH1 / 456 and DIN EN 574 |
| LED                     | Mains, channel 1 and channel 2   |
| Ambient temperature     | -25°C to +55°C   |
| Switching capacity      | 1500 VA (resistive load)   |
| Contact fuse            | 6.3 A fast-acting or 4 A flow-acting   |
| Operating voltages      | 24 V AC/DC (electronic fuse)<br>48, 115, 230 V AC (galvanic isolation/transformer)                                       |
| Power consumption       | Approx. 2 V A  |
| Pick-up/reverse delay   | <50 ms / <25 ms  |
| Contact rating (max.)   | 6 A, 250 V AC, 24 V DC   |
| Contact rating (min.)   | 6 mA   |

The safety relay for two-hand circuits from type I to III c is available in many voltage variants.

EN ISO 13849-1: PLe, Cat. 4 | MTTFd: 36.45 years /high, DC: 99 % /high | CCF: met

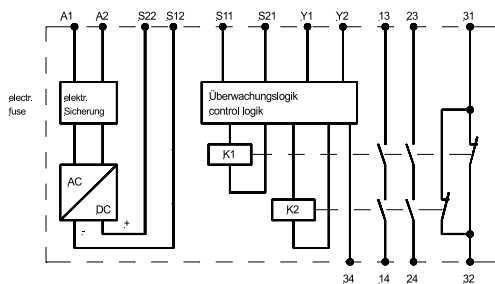

|                    |            |         |              |          |
|--------------------|------------|---------|--------------|----------|
| Operating voltages | 24 V AC/DC | 48 V AC | 110-127 V AC | 230 V AC |
| Art. no.           | 45062      | 45305   | 45307        | 45068    |

## SAFE CZ



|                         |   |
|-------------------------|---|
| Application             | Wear-free, as with semiconductor outputs and logical connections for type II or IIIc  |
| Approval                | TÜV, UL, C-UL   |
| Contacts                | 4 safety semiconductor outputs (OSSD)<br>Visual switching status indication and mains control via LED<br>Wear-free semiconductor outputs, "AND" connection between multiple devices from the SAFE C family possible, autostart possible |
| Special characteristics | Mains, channel 1 and channel 2 + warning system   |
| LED                     | -25°C to +55°C  |
| Ambient temperature     | Up to 43 W  |
| Switching capacity      | Short-circuit protected   |
| Contact fuse            | 24 V DC (+ 25 - 20 %) surge protection  |
| Operating voltages      | Approx. 3 W   |
| Power consumption       | <100 ms / <25 ms  |
| Pick-up/reverse delay   | Contact rating (max.)<br>Sum current up to 1.8 A (individual or in total)   |
| Contact rating (max.)   | Contact rating (min.)<br>Unlimited  |

Safety relay for two-hand applications for type II or III c with wear-free semiconductor outputs (OSSD). As a result, the device is suitable for applications with frequent actuations. Safe CZ is available in many voltage variants. Control relay functions can be assumed with the additional AND connection; optionally with manual or automatic start.

EN ISO 13849: PLe, Cat. 4 | MTTFd: 163 years /high | DC: 99 %  
Supplementary information as per EN 61508: SIL3 | PFH: 2.87\*10<sup>-9</sup>/h | PFD: 2.01\*10<sup>-6</sup> 1/h | SFF: 0.9573

|          |       |
|----------|-------|
| Art. no. | 45072 |
|----------|-------|

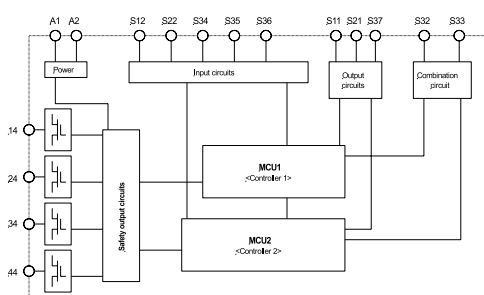

# 5 | Two-hand control circuits



## SAFE FLEX

|                         |   |
|-------------------------|---|
| Application             | Safety relay with optional function variants  |
| Approval                | TÜV, UL, C-UL   |
| Contacts                | 2 normally open, 1 PLC output (PNP)   |
| Special characteristics | Visual switching status indication via LED, visual fault indication via LED, optional monitored and non-monitored start |
| LED                     | Mains, channel 1 IN / OUT, channel 2 IN / OUT, fault  |
| Ambient temperature     | -25°C to +55°C  |
| Switching capacity      | 1500 V A  |
| Contact fuse            | 6 A fast-acting or 4 A flow-acting  |
| Operating voltages      | 24 V DC (+ 20 - 25 %) surge protection  |
| Power consumption       | <3 W  |
| Pick-up/reverse delay   | Emergency off, non-contact safety device, two-hand, safety door guard <= 30 ms  |
| Contact rating (max.)   | 6 A, 250 V AC, 250 V DC   |
| Contact rating (min.)   | 5 mA  |

The following functions are optionally available when wired accordingly:

- Emergency off safety relay Cat. 4
- Safety door guard cat. 4
- Two-hand relay type III c Cat. 4
- Relay for non-contact safety devices/light barriers, Cat. 4 and Cat. 2
- 1-pin safety devices with cycle-based monitoring via test output, Cat. 4
- Monitoring of movement direction through various tolerance ranges for monitoring synchronisation
- Changes to wiring during ongoing operation are recognised as a fault

EN ISO 13849: PL<sub>e</sub>, Cat. 4 | MTTFd: >100 years / high | DC: 99 % / high  
 Supplementary information as per EN 61508: SIL3 | PFH:  $2.15 \cdot 10^{-9} / h$  | SSF: 94.65 %

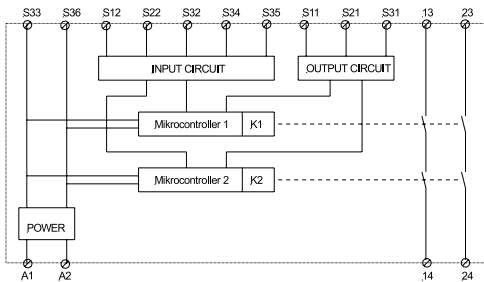

|          |       |
|----------|-------|
| Art. no. | 45332 |
|----------|-------|

# 6 | Contact multiplication in emergency stop circuits, safety door monitoring circuits and other safety circuits

## SAFE X4 / SAFE X4.1



|                         |  |
|-------------------------|--|
| Application             | Extension module as downstream relay for safety relay  |
| Approval                | TÜV, UL, C-UL  |
| Contacts                | 4 normally open, 1 normally closed (return circuit)<br>With (SAFE X4) and without (SAFE X4.1) cross-circuit protection |
| Special characteristics | Simple contact multiplication<br>Compact design in minimum space   |
| LED                     | Channel 1, channel 2 and fault   |
| Ambient temperature     | -25°C to +55°C   |
| Switching capacity      | 1500 VA (resistive load)   |
| Contact fuse            | 10 A fast-acting   |
| Operating voltages      | 48, 115, 230 V AC (galvanic isolation/transformer),<br>24 V AC/DC (no galvanic isolation/with electr. fuse),           |
| Power consumption       | Approx. 4 V A  |
| Pick-up/reverse delay   | - / <15 ms   |
| Contact rating (max.)   | 6 A, 250 V AC, 24 V DC, sum current <16 A  |
| Contact rating (min.)   | 6 mA   |

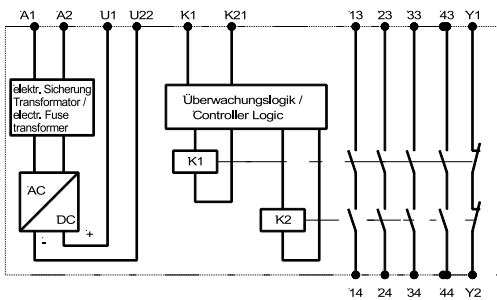

Safe extension of the number of output contacts for all safety relays (including SAFE C types). For safe contact extension, two contacts are required from the device to be extended. Note that this extends the reverse period.

EN ISO 13849-1: PLe, Cat. 4 | MTTFd: 37 years / high | DC: 99 % / high | CCF: met

### SAFE X4

|                    |            |         |              |          |
|--------------------|------------|---------|--------------|----------|
| Operating voltages | 24 V AC/DC | 48 V AC | 110-127 V AC | 230 V AC |
| Art. no.           | 45019      | 453195  | 45197        | 45201    |

### SAFE X4.1

|                    |            |         |              |          |
|--------------------|------------|---------|--------------|----------|
| Operating voltages | 24 V AC/DC | 48 V AC | 110-127 V AC | 230 V AC |
| Art. no.           | 45021      | 45196   | 45200        | 45203    |

## SAFE IRZ.2

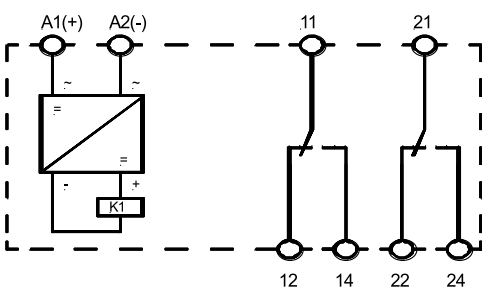

|                         |  |
|-------------------------|--|
| Application             | Industrial relay with two with two forcibly actuated converters. |
| Contacts                | 2 converters   |
| Special characteristics | Visual mains control via LED<br>Initiator connection             |
| LED                     | Mains  |
| Ambient temperature     | -25°C to +55°C   |
| Switching capacity      | 1250 V A   |
| Contact fuse            | 5 A fast-acting  |
| Operating voltages      | 24 V AC/DC   |
| Power consumption       | 1 W, 1 V A   |
| Pick-up/reverse delay   | <25 ms   |
| Contact rating (max.)   | 5 A, 250 V AC, 24 V DC   |
| Contact rating (min.)   | 100 mA <sup>(*)</sup>  |

Industrial relay with two with two forcibly actuated converters.

|          |       |
|----------|-------|
| Art. no. | 45013 |
|----------|-------|

# 7 | Emergency stop, safety door, light barrier and two-hand control applications

## SAFE FLEX



|                         |   |
|-------------------------|---|
| Application             | Safety relay with optional function variants  |
| Approval                | TÜV, UL, C-UL   |
| Contacts                | 2 normally open, 1 PLC output (PNP)   |
| Special characteristics | Visual switching status indication via LED, visual fault indication via LED, optional monitored and non-monitored start |
| LED                     | Mains, channel 1 IN/OUT, channel 2 IN/OUT, fault  |
| Ambient temperature     | -25°C to +55°C  |
| Switching capacity      | 1500 V A  |
| Contact fuse            | 6 A fast-acting or 4 A flow-acting  |
| Operating voltages      | 24 V DC (+ 20 - 25 %) surge protection  |
| Power consumption       | <3 W  |
| Pick-up/reverse delay   | Emergency off, non-contact safety device, two-hand, safety door guard <= 30 ms  |
| Contact rating (max.)   | 6 A, 250 V AC, 250 V DC   |
| Contact rating (min.)   | 5 mA  |

The following functions are optionally available when wired accordingly:

- Emergency off safety relay Cat. 4
- Safety door guard cat. 4
- Two-hand relay type III c Cat. 4
- Relay for non-contact safety devices/light barriers, Cat. 4 and Cat. 2
- 1-pin safety devices with cycle-based monitoring via test output, Cat. 4
- Monitoring of movement direction through various tolerance ranges for monitoring synchronisation
- Changes to wiring during ongoing operation are recognised as a fault

EN ISO 13849: PLe, Cat. 4 | MTTFd: >100 years/high | DC: 99 % / high  
 Supplementary information as per EN 61508: SIL3 | PFH:  $2.15 \cdot 10^{-9} \frac{1}{h}$  | SSF: 94.65 %

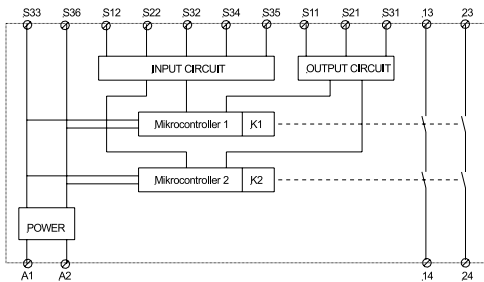

|          |       |
|----------|-------|
| Art. no. | 45332 |
|----------|-------|

## SAFE FLEXT (outlook)



|                         |  |
|-------------------------|--|
| Application             | Safety relay for actuating e.g. proximity switches/distance sensors (ultrasounds, capacitive, inductive)                                     |
| Approval                | TÜV (UL, C-UL requested)   |
| Contacts                | 4 normally open (1x basic isolation), 2 normally open delayed, 1 normally closed (basic isolation), 1 semiconductor auxiliary output delayed |
| Special characteristics | Visual switching status indication via LED<br>Visual fault indication via LED, autostart possible  |
| LED                     | -  |
| Ambient temperature     | -25°C to +55°C   |
| Switching capacity      | -  |
| Contact fuse            | 6 A fast-acting or 4 A flow-acting   |
| Operating voltages      | 24 V DC (+ 20 - 25 %) surge protection   |
| Power consumption       | -  |
| Pick-up/reverse delay   | -  |
| Contact rating (max.)   | -  |
| Contact rating (min.)   | 5 mA   |

EN ISO 13849-1 / DIN EN 61508 / DIN EN 62061: parameters in preparation

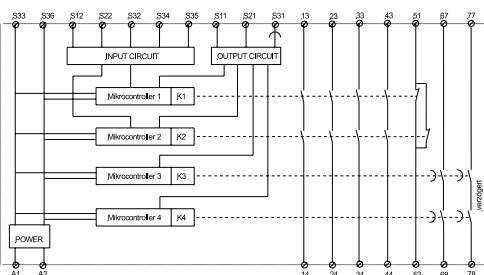

|          |       |
|----------|-------|
| Art. no. | 4638X |
|----------|-------|

## SAFE SM (outlook)

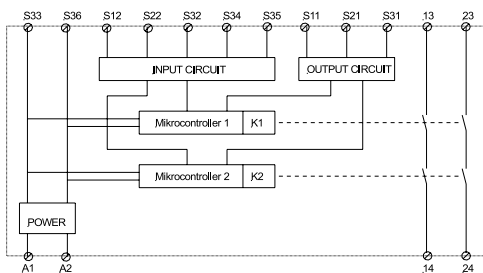

|                         |   |
|-------------------------|---|
| Application             | For 2 non-safe sensors on any machine part  |
| Approval                | (TÜV, UL, C-UL requested)   |
| Contacts                | 2 normally open, 1 PLC output (PNP)   |
| Special characteristics | Visual switching status indication via LED<br>Visual fault indication via LED<br>Optional monitored and non-monitored start |
| LED                     | Mains, channel 1 IN/OUT, channel 2 IN/OUT, fault  |
| Ambient temperature     | -25°C to +55°C  |
| Switching capacity      | 1500 V A  |
| Contact fuse            | 6 A fast-acting or 4 A flow-acting  |
| Operating voltages      | 24 V DC (+ 20 - 25 %) surge protection  |
| Power consumption       | < 3 W   |
| Pick-up/reverse delay   | Frequency-dependent   |
| Contact rating (max.)   | 6 A, 250 V AC, 250 V DC   |
| Contact rating (min.)   | 5 mA  |

SAFE SM is a safe standstill monitor. This device recognises a safe speed. Digital switches, such as inductive sensors or non-contact safety devices, are supported. The device is designed with two channels, so two digital switches are required. Four safe speeds are identified – 0.2 Hz, 0.5 Hz, 1.0 Hz and 2.0 Hz: Switching is executed through the configuration input circuit. Safe sensors are not required. The SAFE SM determines the speed at any machine part instead of right on the motor. This means that drive breaks are also identified. Rotary and translation movements can be monitored.

EN ISO 13849-1: PLe, Cat. 4 | parameters in preparation

Art. no.

45293

# 9 | Multi-functional safety relay with optional properties for lift applications

**NEW**

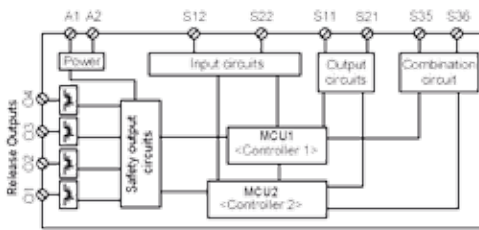

## SAFE GL

|                                 |   |
|---------------------------------|---|
| Application                     | Multi-functional safety relay with optional properties for lift applications  |
| Approval                        | SIL3, SIL <sub>cat</sub> 3, PLe, Cat4 possible, EN81-20, EN81-50, EN ISO 13849, EN 61508, EN 62061, MTTFd=1268a; PFH=3.58 E-09 1/h;   |
| Outputs                         | 4 OSSDs (secure semiconductor outputs), short-circuit protected<br><ul style="list-style-type: none"> <li>• 3 normally open direct, 1 normally closed direct</li> </ul>   |
| Functions, optional             | <ul style="list-style-type: none"> <li>• Emergency off and safety door guard                             <ul style="list-style-type: none"> <li>- 2 channels, 4-wire   2 channels, 3-wire   1 channel, 2-wire</li> </ul> </li> <li>• Non-contact safety device                             <ul style="list-style-type: none"> <li>- Type 4</li> <li>- Type 2</li> </ul> </li> <li>• Safety mat</li> </ul> |
| Start behaviour                 | Optionally with automatic or manual start (monitored)   |
| Special characteristics         | Visual status indication via LED, visual fault indication via LED (fault code), monitoring of external fuses  |
| Ambient temperature             | 0°C to +65°C  |
| Switching capacity              | 4x 400 mA, 24 V DC  |
| Operating voltages              | 24 V DC ± 20 %  |
| Power consumption               | Approx. 3 W (idle)  |
| Reverse delay (Direct contacts) | 20 ms   |
| Housing (W x H x D)             | 18 x 90 x 58 mm   |

The SAFE GL is the variant with lift approval according to EN 81.

|                 |       |
|-----------------|-------|
| <b>Art. no.</b> | 45335 |
|-----------------|-------|

## Competence across the entire EMS spectrum

In our development department, we engineer, design, conceptualise and plan the entire range of electronic manufacturing services (EMS).

From conceptualising and planning circuit boards, to prototypes and manufacturing high-quality end products. Our customers also benefit from our comprehensive expertise and experience in the optimisation of existing concepts and consultation for mechanical design.

In developing our products and series, we set great store by their quality, as well as by efficient cost and time management. Customised solutions are our specialty. After all, every project has its own requirements. We flexibly respond to your requests and develop just the right solution for you.

Our experienced experts and competent employees manage projects from various industries: automotive, mechanical engineering, medical technology, industry and sensor systems.

In addition, we can tailor testing equipment to individual customer requirements and requests. Together, we develop testing concepts and finished test adapters that enable inexpensive series testing for our customers.

- Software and hardware development in line with the highest safety standards such as SIL3, PLe and EN81
- In-house prototype construction
- In-house test device construction
- Consultation for mechanical constructions (housing, encapsulating receptacle etc.)
- Approvals: TÜV / UL / C-UL



# Housing dimensions

| Name                 | B (mm) |
|----------------------|--------|
| SAFE 2.2             | 22.5   |
| SAFE 4/4.1           | 22.5   |
| SAFE 4 eco/4.1 eco   | 22.5   |
| SAFE 4.2 eco/4.3 eco | 22.5   |
| SAFE 5/5.1           | 22.5   |
| SAFE C1/CL/CM/CZ     | 22.5   |
| SAFE M/M.1           | 22.5   |
| SAFE L.2             | 22.5   |
| SAFE X4/4.1          | 22.5   |
| SAFE Z.2             | 22.5   |
| SAFE FLEX            | 22.5   |
| SAFE FLEX L          | 22.5   |
| SAFE FLEX T          | 45     |
| SAFE SM              | 22.5   |
| SAFE T/T ON          | 35     |

Figure

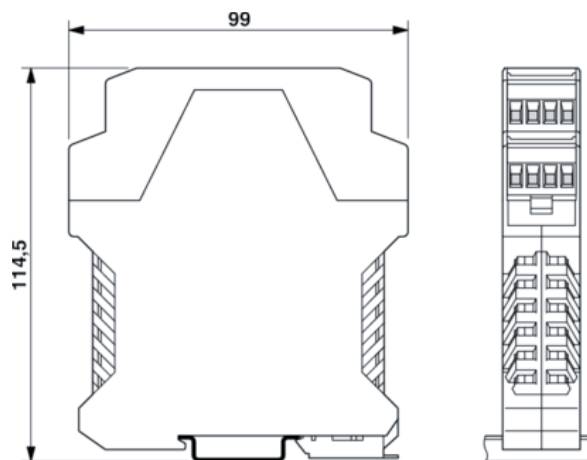

|                            |      |
|----------------------------|------|
| SAFE 1                     | 22.5 |
| SAFE 1.1                   | 22.5 |
| SAFE 2                     | 22.5 |
| SAFE 2.1                   | 22.5 |
| SAFE IR.2<br>(8 terminals) | 22.5 |

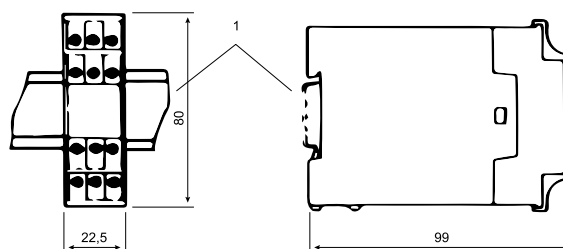

|          |    |
|----------|----|
| SAFE S.6 | 45 |
|----------|----|

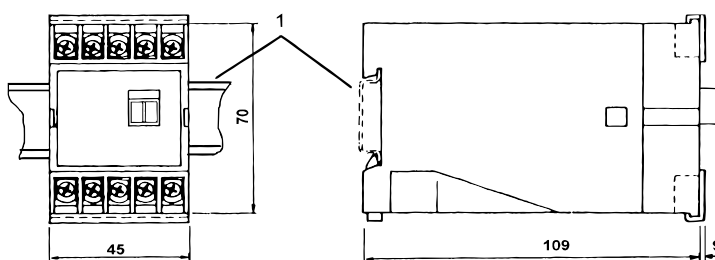

|         |      |
|---------|------|
| SAFE G1 | 17.9 |
| SAFE G2 |      |
| SAFE GT |      |
| SAFE GL |      |

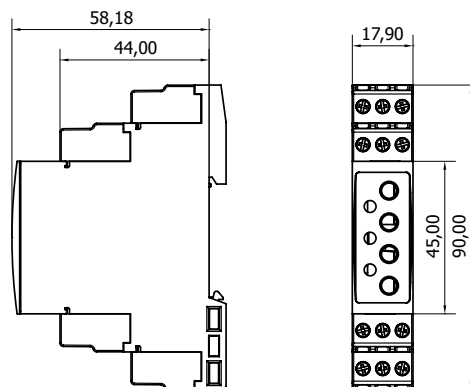

**Legend:**

1 - hat rail according to DIN 46 277

Print date: 10\_2018 | Devices listed in the brochure are subject to change. This brochure replaces all previous brochures.

As the text and images in this brochure only serve illustration purposes, we do not assume liability for any errors.

| Name         | Voltage      | CM art. no. |       |
|--------------|--------------|-------------|-------|
| SAFE 4       | 24 V AC/DC   | 46353       | 45042 |
| SAFE 4       | 110 V AC     | 46355       | 45045 |
| SAFE 4       | 230 V AC     | 46357       | 45255 |
| SAFE 4.1     | 24 V AC/DC   | 46354       | 45046 |
| SAFE 4.1     | 110 V AC     | 46356       | 45052 |
| SAFE 4.1     | 230 V AC     | 46358       | 45054 |
| SAFE 4.1 eco | 24 V AC/DC   | 45069       |       |
| SAFE 4.2 eco | 24 V AC/DC   | 45317       |       |
| SAFE 4.2 eco | 115 V AC     | 45318       |       |
| SAFE 4.2 eco | 230 V AC     | 45319       |       |
| SAFE 4.3 eco | 24 V AC/DC   | 45320       |       |
| SAFE 4.3 eco | 115 V AC     | 45321       |       |
| SAFE 4.3 eco | 230 V AC     | 45322       |       |
| SAFE 5       | 24 V AC/DC   | 45228       |       |
| SAFE 5.1     | 24 V AC/DC   | 45232       |       |
| SAFE C1      | 24 V DC      | 45327       |       |
| SAFE 1       | 24 V AC/DC   | 45037       |       |
| SAFE 1.1     | 24 V AC/DC   | 45036       |       |
| SAFE 2       | 24 V AC/DC   | 45038       |       |
| SAFE 2.1     | 24 V AC/DC   | 45039       |       |
| SAFE S.6     | 24 V AC/DC   | 45244       |       |
| SAFE S.6     | 48 V AC      | 45035       |       |
| SAFE S.6     | 110-127 V AC | 45245       |       |
| SAFE S.6     | 230 V AC     | 45246       |       |
| SAFE G1      | 24 V DC      | 45337       |       |
| SAFE G2      | 24 V DC      | 45338       |       |
| SAFE GT      | 24 V DC      | 45336       |       |
| SAFE GL      | 24 V DC      | 45335       |       |

| Name        | Voltage      | CM art. no. |       |
|-------------|--------------|-------------|-------|
| SAFE TN     | 24 V AC/DC   | 45024       |       |
| SAFE TA     | 24 V AC/DC   | 45025       |       |
| SAFE TR     | 24 V AC/DC   | 45209       |       |
| SAFE TU     | 24 V AC/DC   | 45026       |       |
| SAFE T ON   | 24 V AC/DC   | 45215       |       |
| SAFE FLEX T | 230 V AC     | 4638X       |       |
| SAFE CM     | 24 V DC      | 45071       |       |
| SAFE M      | 24 V AC/DC   | 46365       | 45029 |
| SAFE M      | 115 V AC     | 46366       | 45240 |
| SAFE M.1    | 24 V AC/DC   | 46367       | 45034 |
| SAFE 2.2    | 24 V AC/DC   | 46387       |       |
| SAFE L.2    | 24 V AC/DC   | 45058       |       |
| SAFE CL     | 24 V DC      | 45328       |       |
| SAFE Z.2    | 24 V AC/DC   | 45062       |       |
| SAFE Z.2    | 48 V AC      | 45305       |       |
| SAFE Z.2    | 110-127 V AC | 45307       |       |
| SAFE Z.2    | 230 V AC     | 45068       |       |
| SAFE CZ     | 24 V DC      | 45072       |       |
| SAFE X4     | 24 V AC/DC   | 45019       |       |
| SAFE X4     | 48 V AC      | 45195       |       |
| SAFE X4     | 110-127 V AC | 45197       |       |
| SAFE X4     | 230 V AC     | 45201       |       |
| SAFE X4.1   | 24 V AC/DC   | 45021       |       |
| SAFE X4.1   | 48 V AC      | 45196       |       |
| SAFE X4.1   | 110-127 V AC | 45200       |       |
| SAFE X4.1   | 230 V AC     | 45203       |       |
| SAFE IRZ.2  | 24 V AC/DC   | 45013       |       |
| SAFE FLEX   | 24 V DC      | 45332       |       |
| SAFE FLEX L | 24 V DC      | 46364       |       |
| SAFE SM     | 24 V DC      | 45293       |       |

# Production

- **SMD soldering**  
2 x Siemens SIPLACE CF  
(up to design 0201)  
2 x Siemens SIPLACE S27
- **Reflow soldering**  
2 x SMT Quattro Peak M (N2)  
with nitrogen soldering
- **RoHS soldering**  
SEHO MaxiWave 2335 C
- **Silkscreen**  
2 x EKRA X4
- **THT manual soldering**
- **Automated function test**  
Function tester and ICT device  
Reinhardt KMFT 470 ICT
- **AOI tester**  
ORBOTECH 8-22  
VISCOM  
ZEISS
- **Automatic tester**  
2 x Flying Probe Tester TAKAYA
- **Casting, adhesion, coating etc.**  
2 x BARTEC  
3 x VIEWEG
- **Labelling and packaging**

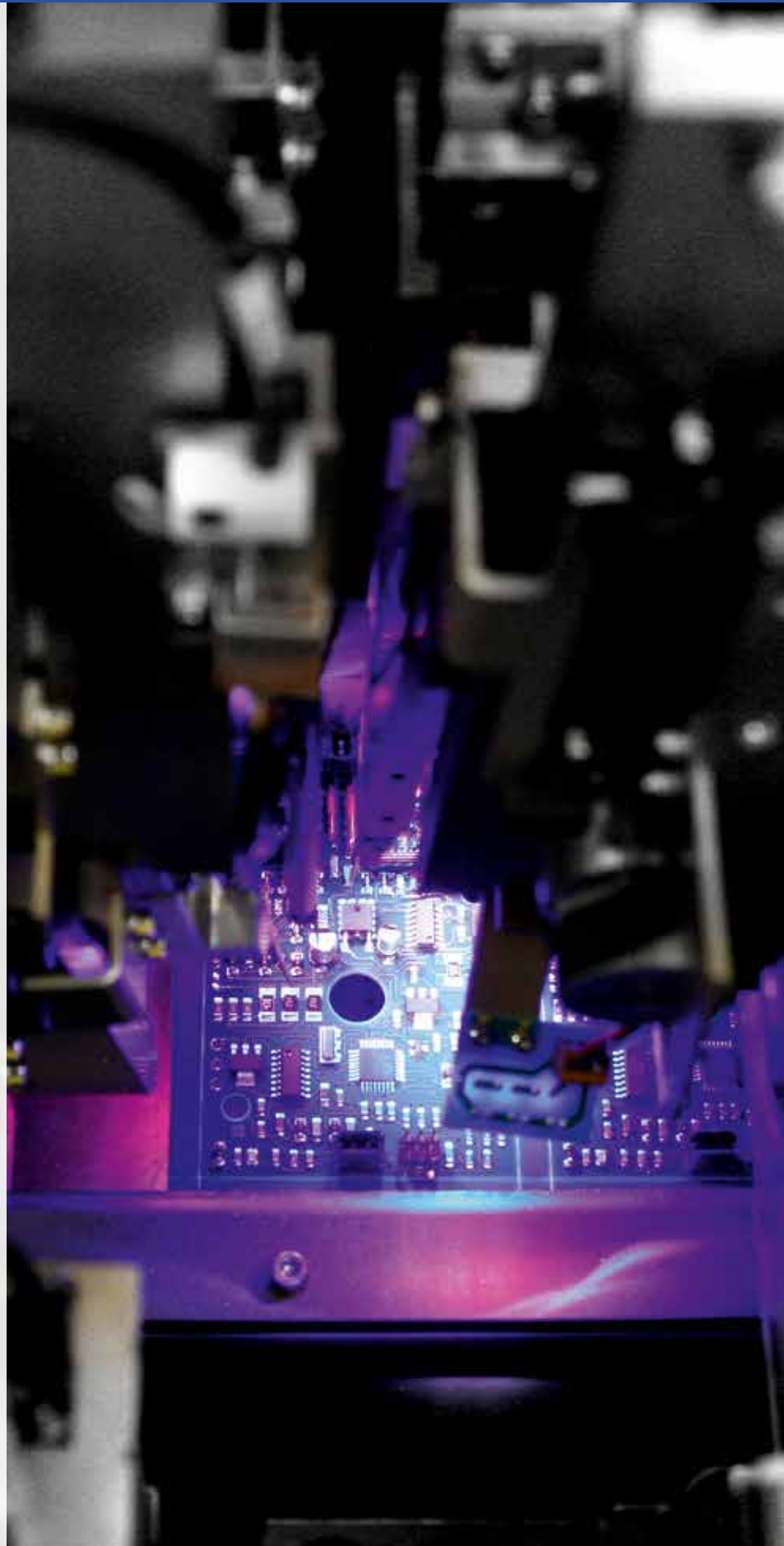



## Systematic cable assembly!

Our services range from simple cable assembly to complex cable harnesses with plugs, contacts or even cable-end sleeves for virtually all applications.

- Automotive
- Mechanical engineering
- Medical technology
- Industry
- Sensor systems

Whether miniature strands, flat cables or cable kits: profound expertise, flexibility and perfection ensure the highest of quality standards. Modern machinery allows us to offer customised solutions.

### Key activities

- Full automation: labelling, stripping, tinning and crimping
- Single strands with crimp technique in various versions
- Flat cable with labelling
- Production of complex cable harnesses
- High-voltage testing with WEETECH W434
- Sensors with casting compound
- Infrared shrinkage
- Packaging in ESD standard
- Customised packaging and labelling





300 Roundhill Drive  
Rockaway, NJ 07866  
Tel: 973-586-2500  
[www.norstat.com](http://www.norstat.com)

Certified to DIN EN ISO 9001

Approvals: TÜV/UL/C-UL

**TÜV**  
type-  
tested

